



# **dsPIC<sup>®</sup>**

## **Digital Signal Controller**

# **Introduction to Switch Mode Power Supplies (SMPS)**

© 2006 Microchip Technology Incorporated. All Rights Reserved.

Introduction to Switch Mode Power Supply

Slide 1

Welcome to the Introduction to the dsPIC Switch Mode Power Supply Design web seminar.

## Session Agenda

- **Linear versus Switch Mode Power Supplies**
- **Common SMPS DC-DC Converters**
- **Common SMPS AC-DC Converters**

This is the agenda for this course. We will start by comparing the characteristics of linear and switch mode power supplies.

We will then discuss the basic design features of some common DC/DC converter designs.

Then we will cover some typical designs used in AC to DC converters.

When discussing various SMPS designs, we often use the word “topologies” to describe the basic circuit configurations of switches (transistors), magnetic components (inductors and transformers), and capacitors.

## Overview

- **Switching Power Supplies**
  - **Voltage regulation via controlled power transfer**
  
- **Linear Power Supplies**
  - **Voltage regulation via power dissipation**
  - **Power dissipation creates Heat problems**

Linear power supplies use power dissipation to achieve voltage regulation.

A linear power supply must be designed to supply enough voltage to overcome conditions of low input voltage while supplying maximum rated load current. There are additional voltage drops in the rectifiers, the linear regulator circuit, and the transformer. Finally, the filter capacitors have a ripple voltage imposed by the rectified AC. The lowest point of the ripple voltage must be higher than the minimum required for the regulator circuit.

The linear regulator works like a variable resistor, dropping the input voltage to the level required by the output.

To meet all of the worst case conditions, a linear supply, under typical conditions may dissipate as heat an amount of power equal to the power consumed by the load. Under high input voltage conditions, the power lost as heat dissipation may be double that of the load !

Switch Mode power supplies use the principle of quantized power transfer to implement voltage regulation.

Through the control of transistors operating as switches (on or off) with energy storage components such as inductors and capacitors, a switch mode power supply transfers just enough energy from the input to the output to achieve the desired output voltage and currents.

## Why Switch Mode Power Supplies?

### SMPS Advantages:

- **More Efficient**
- **Smaller Size**
- **Less Weight**
- **Less Cost**
- **Easier PFC support**

Switch Mode power supplies offer the advantages of smaller size, weight, and cost while achieving much higher power efficiencies.

Almost any product can benefit from a reduction in weight and size.

Switch mode power supplies have a more complex circuit design than linear power supplies, but at medium to high power levels, the cost and complexity of dealing with high heat dissipation outweighs a more complex circuit.

The improvement in energy efficiency is often a required feature for many products, especially battery powered items where battery life is a critical selling point to a customer. Energy efficiency is also becoming a government mandated feature, such as the United State's "Energy Star" program.

Power Factor Correction (PFC) is becoming a government mandated requirement for power supplies in countries around the world. PFC is the process that insures that the input voltages and currents from the AC power line into a power supply are in phase to achieve a "Unity Power Factor". PFC is very costly to achieve in a linear power supply.

## AC/DC Power Supply Comparison

Performance Benefits:	Linear	Switched
Power Density (Watts/cu-in)	0.87	3.1
Efficiency (%)	35	85
Input Voltage Range (VAC)	104 - 132	85 - 265

The power density of SMPS power supplies is constantly improving with the increasingly higher switching frequencies in modern designs. Linear power supplies based on 60 Hertz magnetics have not changed in size in 50 years.

The efficiency for new SMPS power supply designs are moving into the 90% range. The efficiency for linear supplies has changed little over the past decades.

Linear power supplies have difficulty supporting wide input voltage ranges. Typically, many input transformer voltage taps (selections) are required along with a switch mechanism to enable the power supply to function in world markets. (Japan is 100 VAC 50/60 Hertz, USA is 120 VAC 60 Hertz, and Europe is 230VAC 50 Hertz).

## Common SMPS DC-DC Converter Topologies

- **Buck**
- **Boost**
- **Buck-Boost**
- **Push-Pull**

Power supplies that convert a DC input voltage to a DC output voltage called “converters”.

The DC to DC switch mode converter may be implemented via a large selection of circuit designs. These basic designs are called “Topologies”.

The most common and basic topology is the “Buck” converter. The buck converter is a step-down converter that changes a higher input voltage to a lower output voltage,

The “Boost” converter is similar to a Buck converter but instead of stepping down the input voltage, the output voltage is higher than the input voltage.

The “Buck-Boost” provides a negative output voltage relative to the input voltage.

The “Push-Pull” converter is a transformer based converter that is typically used for higher power applications. By using a transformer, any combination of input to output voltages and polarities is achievable.

# Buck DC to DC Converters

Step down converter

Switch ON

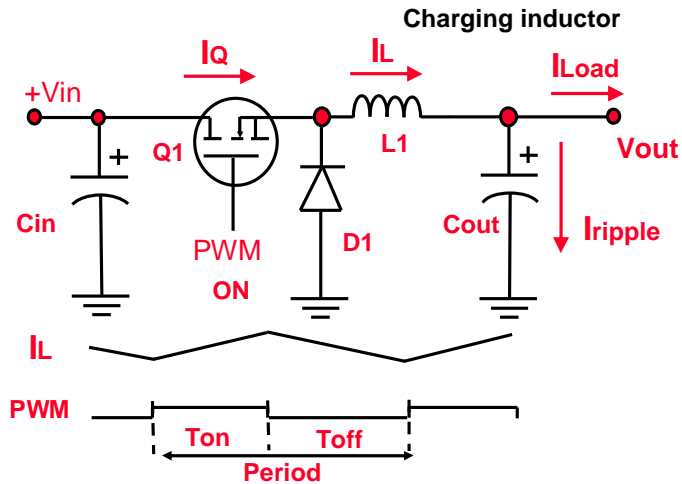

This slide shows a Buck converter when the transistor  $Q1$  is turned on by the PWM signal. When  $Q1$  is turned on, the current begins to flow from  $V_{in}$  through the transistor, through the inductor  $L1$ , and into the output capacitor and the load.

The inductor  $L1$  controls the current flow. The applied voltage across the inductor causes the current to increase linearly with time. Think of this process as "Charging Up the Inductor". The inductor current flow charges the output capacitor which raises the output voltage.

A control circuit (not shown here) monitors the output voltage, and when the output voltage reaches the desired value, the PWM signal is deasserted.

Note that the frequency of the PWM signal must be high enough to insure that the current through the inductor  $L1$  does not become too large.

# Buck DC to DC Converters

Step down converter

Switch OFF

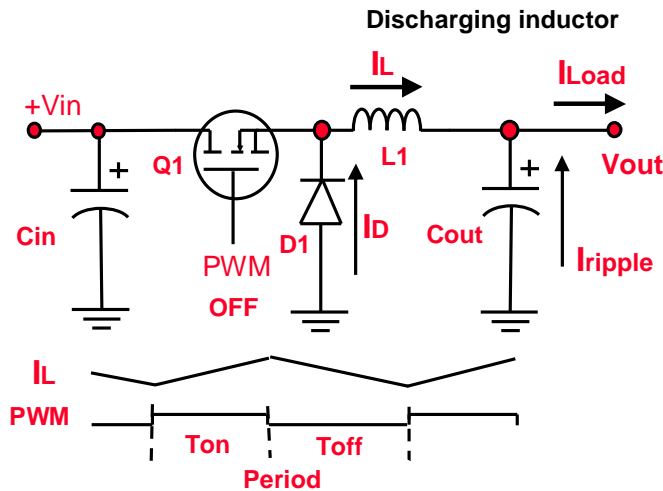

This slide shows the Buck converter after the pwm signal is deasserted and the transistor Q1 is turned off. The current no longer can flow from the Vin source, but the inductor current must continue to flow.

As Q1 turns off, the inductor pulls current from the ground through the diode (D1). The voltage across the inductor is now reversed, so the current begins to decrease linearly with time.

The inductance value must be larger enough for the given pwm frequency to insure that the inductor current does not drop to zero before the start of the next pwm cycle. If the current was to drop to zero, then the control mode is called "Discontinuous". The discontinuous mode of operation can be more difficult to control than the "Continuous" mode where the current through the inductor is always greater than zero.

The choice of the inductor value relative to the pwm frequency is important. A larger inductance value makes L1 physically larger and heavier, but it will reduce the current ripple that flow into and out of the output capacitor, reducing the resultant ripple voltage, and reducing the heat dissipation the the output capacitor.



## Buck DC to DC Converters

$$V_{out} = V_{in} \cdot D$$

Where:

$$D = \text{PWM dutycycle} = T_{on} / (T_{on} + T_{off})$$

Note: range of duty cycle = 0 to 1

The ideal output voltage for Buck converter is the product of the input voltage multiplied by the duty cycle of the transistor. By inspection, the output voltage will equal the input voltage if the transistor Q1 is always turned on. If Q1 is always off, then the output voltage will be zero.

In reality, there are voltage drops across the transistor, and the inductor that increase with increasing load current.

## Boost DC to DC Converters

Step up converter

Switch ON

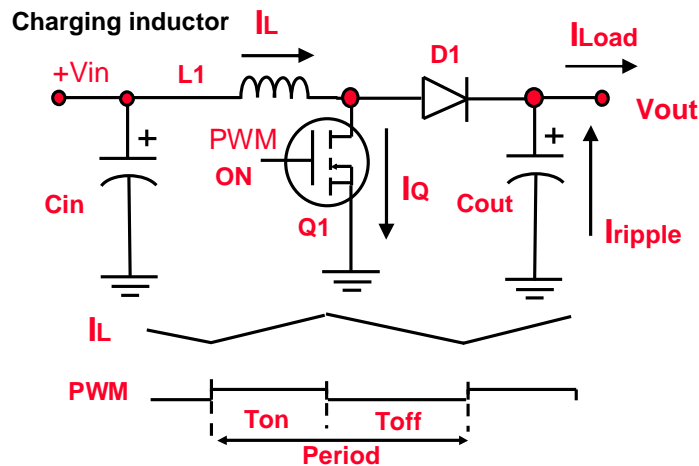

The Boost converter provides output voltages that are greater than the input voltage.

When the transistor  $Q_1$  is turned on, the  $V_{in}$  voltage is applied across the inductor which causes the inductor current to increase. While the current is flowing through  $L_1$  and  $Q_1$ , the inductor is being "charged up".

While  $Q_1$  is turned on, the diode  $D_1$  is reverse biased so no current flows through the diode. The output capacitor  $C_{out}$  supplies the current to the load.

As compared to a Buck converter, a Boost converter places more ripple current on the output capacitor. The output capacitor must be sized large enough to supply all of the load current while the transistor is turned on and still meet the output voltage ripple requirements.

## Boost DC to DC Converters

Step up converter

Switch OFF

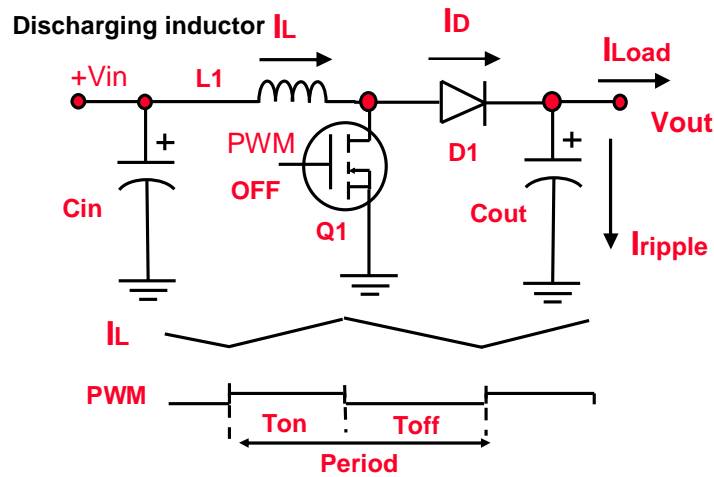

In the Boost converter after the transistor is turned off, the inductor's current will continue to flow. The inductor current will forward bias the diode and the current flows into the output capacitor and the load.

The inductor's current flows "Up-Hill", charging the output capacitor, and raises the output voltage.

## Boost DC to DC Converters

$$V_{out} = V_{in} / (1 - D)$$

Where:

$$D = \text{PWM duty cycle} = T_{on} / (T_{on} + T_{off})$$

Note: range of duty cycle = 0 to < 0.8

In a Boost converter, the output voltage increases with increasing duty cycle values.

The output voltage will be less than the ideal equation because of voltage drops across the inductor and the diode.

The duty cycle is typically less than 0.8 to allow time for the inductor current to fall to zero. If the inductor current does not fall to zero on each pwm cycle, the magnetic core can accumulate a magnetic field that saturates the core material. Core saturation will cause the inductor and the circuit to fail.

Boost converters typically operate in a Discontinuous mode where the inductor current drops to zero before the start of the next pwm cycle as compared to Buck converters that usually operate in a Continuous mode.

Operation of a Boost converter in Continuous mode may experience oscillations unless the bandwidth of the control loop is greatly reduced, and the inductor current is properly limited.

# Buck Boost DC to DC Converters

Inverting converter

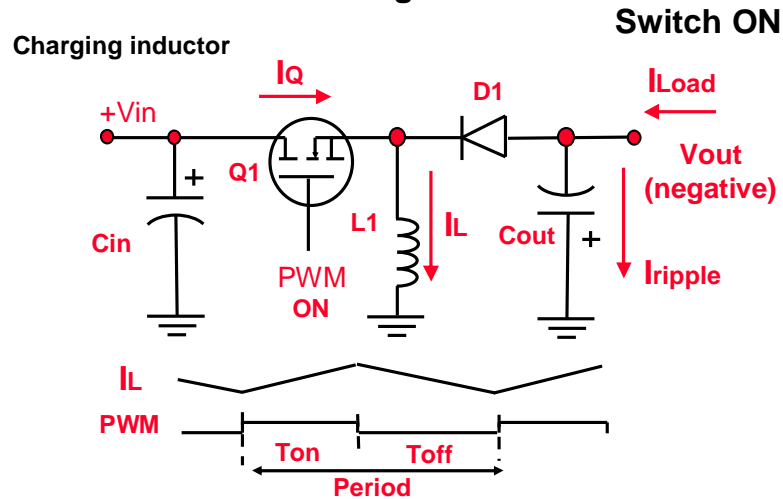

The Buck-Boost converter is similar to the Boost converter except that a negative output voltage is generated. The Buck-Boost converter, as compared to the Buck and the Boost converters, is the only converter where there is no direct current flow from the input supply ( $V_{in}$ ) to the output load. All of the energy transfer is via the inductor  $L1$ .

When  $Q1$  turns on, the current flows through the transistor and the inductor, charging up the stored energy in the inductor.

While  $Q1$  is turned on, the diode  $D1$  is reverse biased and no current flows through  $D1$ . The output capacitor  $C_{out}$  must supply all of the current to the load at this time.

# Buck Boost DC to DC Converters

## Inverting converter

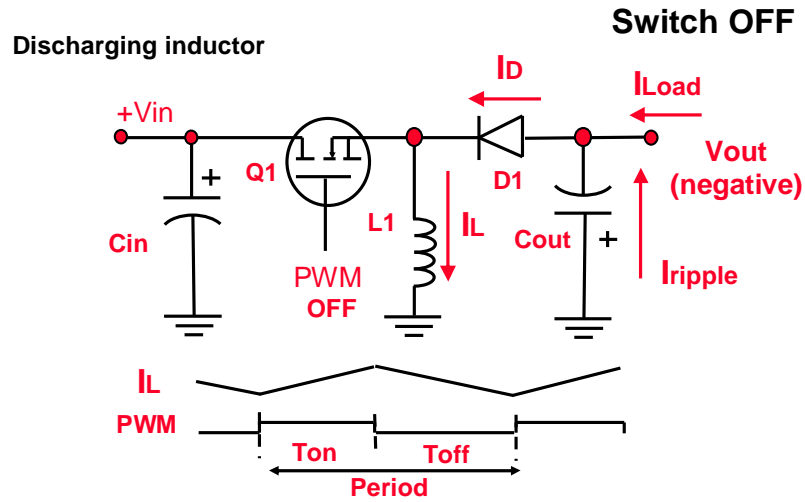

When the transistor  $Q1$  turns off, the inductor current flow will forward bias the diode  $D1$  causing it to conduct. The current flows from the load, through the diode, and then through the inductor.

# Buck Boost DC to DC Converters

## Inverting converter

$$V_{out} = -V_{in} \cdot D / (1 - D)$$

Where:

$$D = \text{PWM duty cycle} = T_{on} / (T_{on} + T_{off})$$

Note: range of duty cycle = 0 to < 0.8

In a Buck-Boost converter, the output voltage increases with increasing duty cycle values.

The output voltage will be less than the ideal equation because of voltage drops across the inductor and the diode.

The duty cycle is typically less than 0.8 to allow time for the inductor current to fall to zero. If the inductor current does not fall to zero on each pwm cycle, the magnetic core can accumulate a magnetic field that saturates the core material. Core saturation will cause the inductor and the circuit to fail.

Buck-Boost converters typically operate in a Discontinuous mode where the inductor current drops to zero before the start of the next pwm cycle as compared to Buck converters that usually operate in a Continuous mode.

Operation of a Buck-Boost converter in Continuous mode may experience oscillations unless the bandwidth of the control loop is greatly reduced, and the inductor current is properly limited.

# Push-Pull DC to DC Converters

Isolated converter

Switch #1 ON

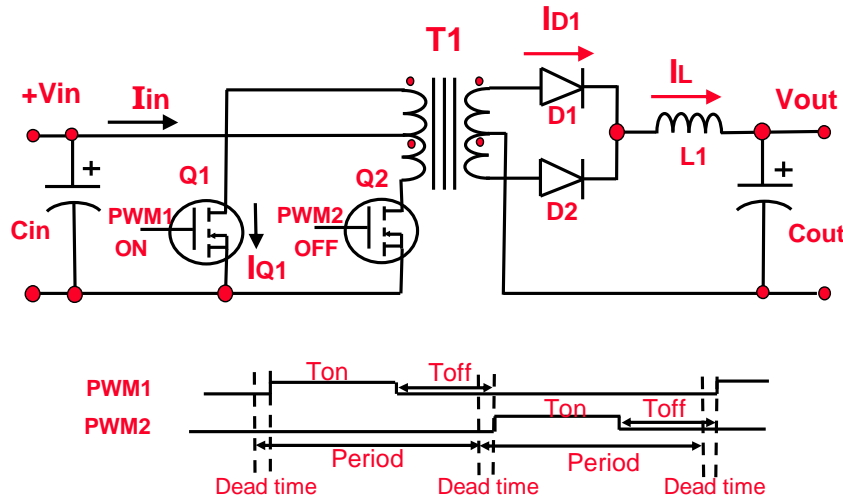

Here we see a Push-Pull DC-DC converter. The Push-Pull converter's transformer enables any input to output voltage ratio to be obtained. The transformer also provides isolation between the input and output terminals, so any polarity between the input and output terminals is possible.

The Push-Pull converter has two transistors that operate in an alternating fashion. One transistor cycles on and off for one pwm period, and then the other transistor cycles on and off on the next pwm cycle. The current flow through alternating windings in the transformer builds the magnetic flux in one direction and then in the other direction. This action resets the magnetic flux on every cycle so that very high duty cycles can be used.

When Q1 is turned on, the current flow through the transformer transfers energy to the secondary winding of the transformer. The current flows from the secondary winding through the diode D1 and into the inductor, C<sub>out</sub>, and the load.

When Q1 is turned off, the inductor current will continue to flow through the transformer winding and diode D1 until the inductor current drops to zero, or the diode become reversed biased by the action of Q2 turning on.

Note the "dots" drawn next to the transformer windings. These "dots" indicate polarity of the windings. The current flow in a primary winding will match the direction of the current flow in a secondary winding.



# Push-Pull DC to DC Converters

Isolated converter

Switch #2 ON

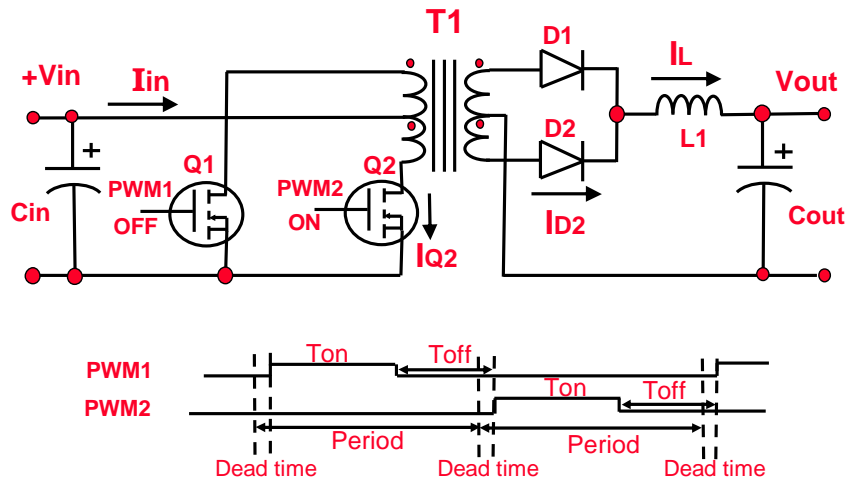

When  $Q_2$  is turned on, the current flow through the transformer transfers energy to the secondary winding of the transformer. The current flows from the secondary winding through the diode  $D_2$  and into the inductor,  $C_{out}$ , and the load.

When  $Q_2$  is turned off, the inductor current will continue to flow through the transformer winding and diode  $D_2$  until the inductor current drops to zero, or the diode become reversed biased by the action of  $Q_1$  turning on.

## Push-Pull DC to DC Converters

### Isolated converter

$$V_{out} = V_{in} \cdot D \cdot N_s / N_p$$

Where:

$$D = \text{PWM duty cycle} = T_{on} / (T_{on} + T_{off})$$

$N_s$  = Number of secondary winding turns

$N_p$  = Number of primary winding turns

Note: range of duty cycle = 0 to 1

The Push-Pull converter output voltage is linear and proportional to the input voltage, the duty cycle, and the turns ratio ( $N_s/N_p$ ) of the transformer. The duty cycle ratio may be any value between 0 and 1.

The transformer provides several advantages:

1. The transformer allows any input to output voltage ratio to be obtained. This is very useful in situations where the input voltage may vary higher and lower than the output voltage such as in battery powered applications. Buck and Boost converters do not provide this capability.
2. The transformer turns ratio also enables the designer to optimize power efficiency in MOSFET based applications by maximizing the duty cycle and minimize  $I^2R$  losses.
3. The transformer provides isolation between the input and output terminals. The isolation permits output polarity independence of the input terminals.
4. The transformer isolation capability can provide safety isolation between low voltage user accessible circuitry and high voltage circuitry.

The disadvantage of the transformer is that it increases the cost, weight, and size of a product while decreasing the efficiency of the power converter.

## Common SMPS AC-DC Converter Topologies

- **FlyBack**
- **Forward Converter**
- **Push-Pull**
- **Half-Bridge**
- **Full-Bridge**

AC to DC power supplies are often called “Off-Line” power supplies because they take power “off of” the AC lines.

AC to DC power supplies combine a transformer isolated DC-DC converter with a AC rectifier circuit that includes diodes (rectifiers), a filter capacitor, and optionally a power factor correction circuit.

Flyback converters are low cost designs typically used for low power applications (5 – 150 watts). Flyback converters also do not require output inductors which saves cost.

The Forward converter can be designed with one or two transistors and is typically used for 100 to 200 watt applications.

The Push-Pull converter has moderate complexity using two transistors and used for medium power applications (150 – 300 watt). This topology subjects the transistors to high voltage stresses ( $>2 \times V_{in}$ ) and is not often used for modern off-line applications.

The Half-Bridge converters have moderate complexity using two transistors and used for medium power applications (150 – 500 watt).

The Full-Bridge converter uses four transistors and is most complex of the common topologies. The Full-Bridge converter supports high power applications ( $> 1 \text{ KW}$ ).

# Fly-Back AC to DC Converter

Isolated converter

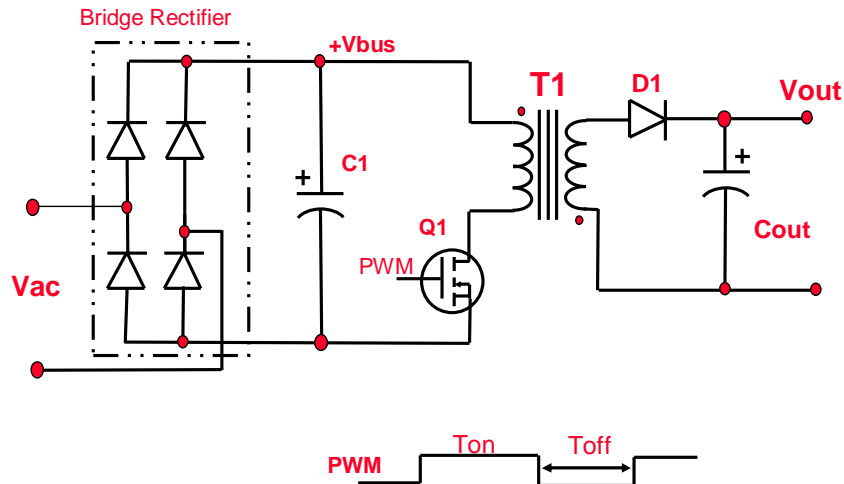

The Fly-back converter uses the transformer as an energy storage device as well as an energy transfer device. This is different from the other transformer based topologies and is recognizable from the polarity dots on the transformer that are reversed from primary to secondary windings.

When transistor Q1 turns on, the output diode will be reversed biased so no output current will flow. The transformer can only function like an inductor and store the energy in the primary winding. While the transistor is on, all of the load current is supplied by the output capacitor Cout.

When transistor Q1 turns off, the current can no longer flow through the primary winding. The collapsing magnetic field reverses voltages on the windings. The diode D1 is forward biased, and the current flows from the secondary winding through the diode and to the load and the output capacitor.

The duty cycle should be less than 50% to prevent unstable operation. The input to output voltage transfer function is more complicated than most other topologies. The design of the transformer is significantly more complicated because of its energy storage functionality.

## 2 Switch Forward AC to DC Converter

Isolated converter

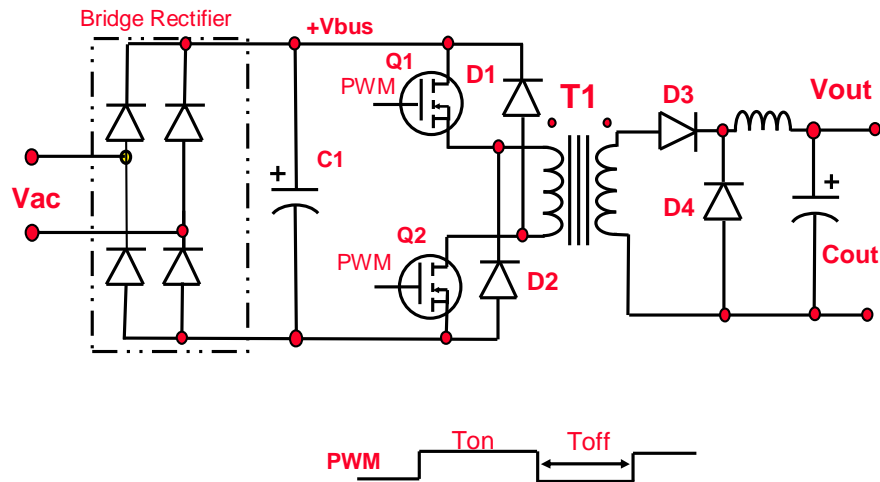

The “2-Switch” forward converter is also called a “Double-Ended” or a “Diagonal Half-Bridge” forward converter. This topology is a very reliable design that does not stress the transistors with voltage spikes.

The two transistors are switch on and off at the same time. When the transistors turn on, power is transferred to the secondary winding, through diode D3, and then to the output capacitor and the load.

When the two transistors are turned off, the magnetic field collapses and the voltages reverse. The leakage inductance energy is fed back through D1 and D2 on the primary side, and through D4 on the secondary side. The transformer flux is always reset with an off time equal to the on time. The maximum duty cycle is 0.5, but typically is limited to 0.4 to insure complete core reset.

The 2-Switch forward converter is an efficient design that does not waste any leakage inductance energy in resistive snubbers.

There is one power pulse transfer of energy per pwm cycle. This requires larger output inductance and capacitance. The core utilization is not optimal since the flux excursions are in the first quadrant of the hysteresis loop (Unipolar).

The input to output voltage transfer function is simple and straightforward.

# Push-Pull AC to DC Converter

## Isolated converter

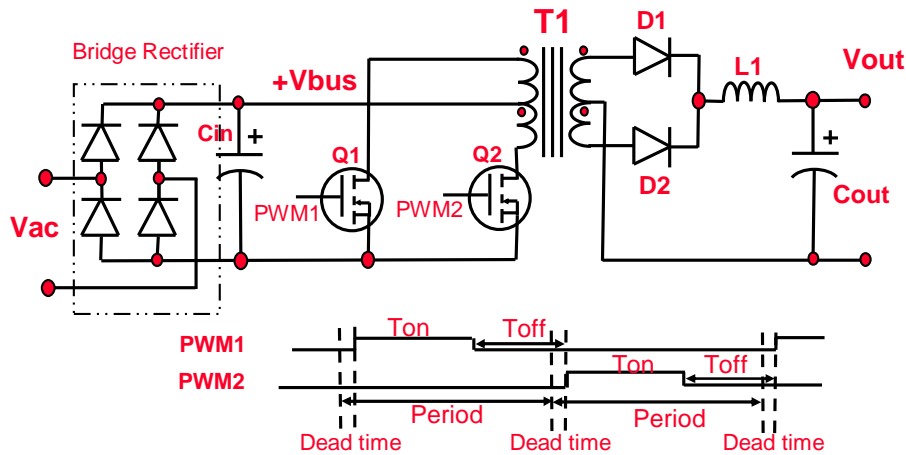

The Push-Pull converter uses two transistors that operate in an alternating fashion. One transistor turns on and then off in one pwm cycle, and then the other transistor in the next pwm cycle turns on and off. The flux is generally reset when the other transistor is turned on, so duty cycles from zero to one are possible.

Both transistors are “ground” referenced which makes driving the transistors easy.

There are two power pulses transferred each cycle, enabling the use of a smaller inductor and output capacitor. The flux hysteresis loop operates in quadrants 1 and 3 so the core utilization is high, allowing the use of a smaller core.

The input to output voltage transfer function is proportional to input voltage, duty cycle, and the transformer turns ratio.

One important consideration is that the Push-Pull design is sensitive to flux imbalance due to slight difference in current flows through the two transistors. Flux imbalance can cause flux saturation. It is highly recommended that current mode control be used to monitor the current flow through the two transistors.

# Half-Bridge AC to DC Converter

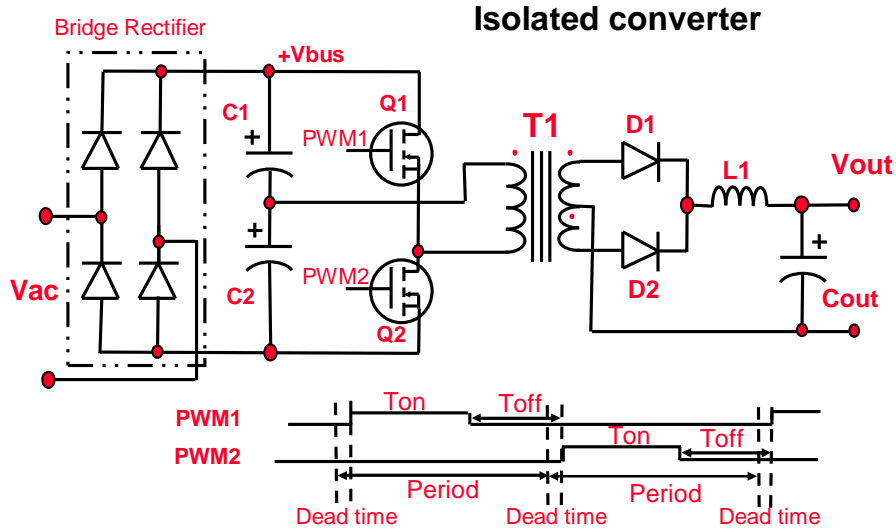

The Half-Bridge converter uses two transistors that operate in an alternating fashion. One transistor turns on and then off in one pwm cycle, and then the other transistor in the next pwm cycle turn on and off. The flux is reset when the other transistor is turned on, so duty cycles from zero to one are possible.

There are two power pulses transferred each cycle, enabling the use of a smaller inductor and output capacitor. The flux hysteresis loop operates in quadrants 1 and 3 so the core utilization is high, allowing the use of a smaller core.

The input to output voltage transfer function is proportional to input voltage, duty cycle, and the transformer turns ratio.

Flux imbalance is not an issue with the Half-Bridge converter because one winding of the transformer is connected to the supply capacitors C1 and C2. If one transistor conducts more current than the other, the voltage at the junction of C1 and C2 will shift up or down in a manner to equalize the current flow through the transistors.

The “Totem Pole” arrangement of the transistors, where one is stacked above the other, is susceptible to current “shoot thru” from the Vbus supply rail to the return, when one transistor is turning off while the other is turning on. To prevent shoot-thru, a dead time (period of no transistor being “on”) must be inserted between each transistor switch transition. Typically the dead time period is about 150 nsec.

The Half-Bridge is a very common and reliable design

# Full-Bridge AC to DC Converter

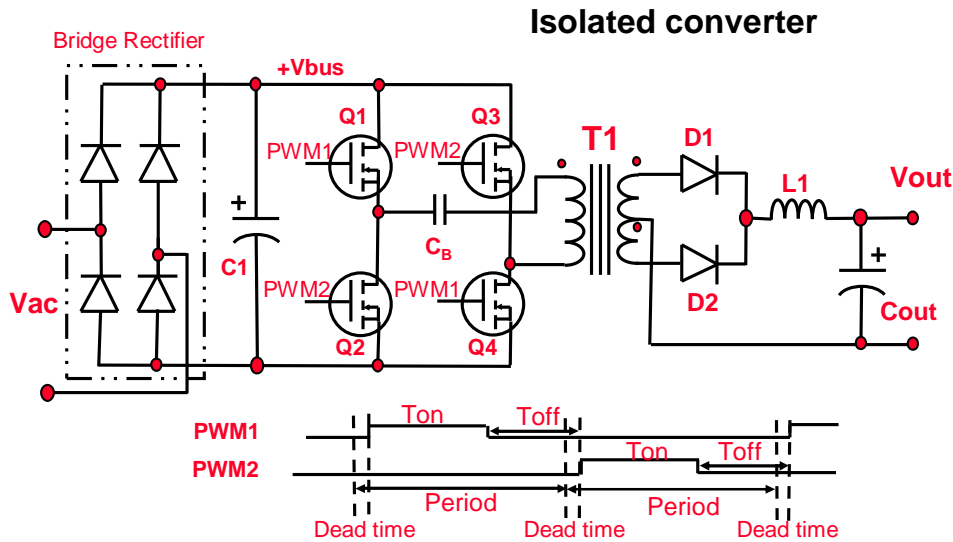

The Full-Bridge converter uses four transistors that operate in an alternating fashion. Two transistors on diagonal sides turn on and then off in one pwm cycle, and then the other transistors in the next pwm cycle turn on and off. The flux is reset when the other transistor pair is turned on, so duty cycles from zero to one are possible.

There are two power pulses transferred each cycle, enabling the use of a smaller inductor and output capacitor. The flux hysteresis loop operates in quadrants 1 and 3 so the core utilization is high, allowing the use of a smaller core.

The input to output voltage transfer function is proportional to input voltage, duty cycle, and the transformer turns ratio.

Flux imbalance is maybe an issue with the Full-Bridge converter. An optional capacitor  $C_B$  may be added so if one transistor pair conducts more current than the other pair, the voltage on  $C_B$  will shift up or down in a manner to equalize the current flow through the transistors.

The “Totem Pole” arrangement of the transistors, where one is stacked above the other, is susceptible to current “shoot thru” from the Vbus supply rail to the return, when one transistor is turning off while the other is turning on. To prevent shoot-thru, a dead time (period of no transistor being “on”) must be inserted between each transistor switch transition. Typically the dead time period is about 150 nsec.

The Full-Bridge is a very common and reliable design



## Key Support Documents

<u>Device Selection Reference</u>	<u>Document #</u>
General Purpose and Sensor Family Data Sheet	DS70083
Motor Control and Power Conv. Data Sheet	DS70082
dsPIC30F Family Overview	DS70043

<u>Base Design Reference</u>	<u>Document #</u>
dsPIC30F Family Reference Manual	DS70046
dsPIC30F Programmer's Reference Manual	DS70030
MPLAB® C30 C Compiler User User's Guide	DS51284
MPLAB ASM30, LINK30 & Utilities User's Guide	DS51317
dsPIC® Language Tools Libraries	DS51456

For more information, here are references to some important documents that contain a lot of information about the dsPIC30F family of devices.

The Family Reference Manual contains detailed information about the architecture and peripherals, whereas the Programmer's Reference Manual contains a thorough description of the instruction set.



## Key Support Documents

Microchip Web Sites: [www.microchip.com/smps](http://www.microchip.com/smps)  
[www.microchip.com/16-bit](http://www.microchip.com/16-bit)

For device data sheets, Family Reference Manuals, and other related documents please visit the following Microchip websites.



# Thank You

*Note: The Microchip name and logo, dsPIC, MPLAB and PIC are registered trademarks of Microchip Technology Inc. in the U.S.A. and other countries. dsPICDEM, dsPICDEM.net, dsPICworks, MPASM, MPLIB, MPLINK and PICtail are trademarks of Microchip Technology Inc. in the U.S.A. and other countries. All other trademarks mentioned herein are property of their respective companies.*

Thank you for attending this Webinar.