

Introduction

This user guide provides complete information about using the Microchip Radio Test 3 tool (MCHPRT3 tool) with the Microchip PIC32MZ1025W1 based Wi-Fi[®] design. The MCHPRT3 tool enables the user to evaluate and demonstrate the Radio Frequency (RF) performance and functionalities of the PIC32MZ1025W1 SoC-based Wi-Fi design.

Note: In this user guide, the MCHPRT3 tool with the PIC32 WFI32E Curiosity Board is only shown as an example.

Table of Contents

Introduction.....	1
1. Quick References.....	3
1.1. Reference Documentation.....	3
1.2. Hardware Requirements.....	3
1.3. Software Requirements.....	3
1.4. Test Equipment.....	3
1.5. Acronyms and Abbreviations.....	3
2. MCHPRT3 Tool Overview.....	4
3. Testing and Calibration of PIC32MZ1025W1 with Wi-Fi Tester using MCHPRT3 Tool.....	5
3.1. MPLAB® X IPE HUT Code Programming Process with In-Circuit Serial Programming™ Header.....	5
3.2. Getting Started with MCHPRT3 Tool GUI for PIC32MZ1025W1.....	7
3.3. Performing RF Test on the PIC32 WFI32E Curiosity Board with MCHPRT3 Tool.....	9
3.4. MCHPRT3 Tool with PIC32MZ1025W1 GUI Demonstration.....	13
3.5. PIC32MZ1025W1 Dynamic Link Library (DLL) Gain Table Information.....	25
3.6. PIC32MZ1025W1 Command Line Interface (CLI) Information.....	26
3.7. PIC32MZ1025W1 Python 3 Information.....	29
4. Document Revision History.....	35
Microchip Information.....	36
The Microchip Website.....	36
Product Change Notification Service.....	36
Customer Support.....	36
Microchip Devices Code Protection Feature.....	36
Legal Notice.....	36
Trademarks.....	37
Quality Management System.....	38
Worldwide Sales and Service.....	39

1. Quick References

1.1 Reference Documentation

For further details, refer to the following:

- *PIC32MZ-W1 Regulatory Certification and Gain Table Application Note* (DS00004235)
Note: This document is released as part of the PIC32MZ1025W104132 Reference Design Package. Refer to the PIC32MZ1025W104132 product package to download it.
- *PIC32 WFI32E Curiosity Board User's Guide* (DS50003028)
- *PIC32MZ W1 MCU and WFI32 Module with Wi-Fi® and Hardware-Based Security Accelerator Data Sheet* (DS70005425)

1.2 Hardware Requirements

- PIC32 WFI32E Curiosity Board ([EV12F11A](#))
- MCP2200 Breakout Module ([ADM00393](#))
- USB-A to micro-USB cable

1.3 Software Requirements

- Windows 10
- Microchip Radio Test 3 tool installer package ([MCHPRT3](#))

1.4 Test Equipment

- Wi-Fi Tester (Litepoint IQxel)

1.5 Acronyms and Abbreviations

Table 1-1. Acronyms and Abbreviations

Acronyms and Abbreviations	Description
CLI	Command Line Interface
DLL	Dynamic Link Library
DUT	Device Under Test
GUI	Graphical User Interface
GND	Ground
HUT	Hardware Under Test
ICSP™	In-Circuit Serial Programming™
MCHPRT3 tool	Microchip Radio Test 3 tool
OTP	One Time Programmable
RSSI	Received Signal Strength Indicator

2. MCHPRT3 Tool Overview

This section provides an overview of the MCHPRT3 tool setup and its components. Install the MCHPRT3 tool. By default, the MCHPRT3 tool installs the PIC32MZ1025W1 package in the C:\Microchip\ folder.

Note: Microchip recommends using the Windows 10 operating system with the MCHPRT3 tool.

The following table lists the MCHPRT3 tool package files:

Table 2-1. MCHPRT3 Tool Package Files

File Name	Description
MCHPRT3.exe file	MCHPRT3 executable file
MCHPRT3_CLI.exe file	MCHPRT3 CLI executable file
uninstall.exe file	Uninstall the MCHPRT3 tool
vc_redist.x86.exe file	Microsoft Visual C++ Redistributable (x86) executable file

The following table lists the PIC32MZ1025W1 package files:

Table 2-2. PIC32MZ1025W1 Package Files

File Name	Description	
<i>examples>python3</i> folder	dll_wrapper folder	Contains conversion files between python3 and the PIC32MZ1025W1 .dll files
	docs folder	Contains python3 example compiled HTML help file
	gui_wrapper folder	Contains individual python3 Graphical User Interface (GUI) files
	engine.py file	Python3 example programming manager file
	PIC32MZ1025W1_GUI.py file	Python3 example file for the PIC32MZ1025W1 GUI
	version.py file	Version information
HEX file (.hex file)	Hardware Under Test (HUT) firmware file	
PIC32MZ1025W1.chm	PIC32MZ1025W1 compiled HTML help file	
PIC32MZ1025W1.dll file	PIC32MZ1025W1 dynamic link library file	
PIC32MZ1025W1_CDECL.dll file	Default calling convention file for C and C++ programs	
PIC32MZ1025W1_CLI.dll file	PIC32MZ1025W1 CLI dynamic link library file	
PIC32MZ1025W1_GUI.dll file	PIC32MZ1025W1 GUI dynamic link library file	
release_note.txt file	Release History	

Note: The MCHPRT3 tool works efficiently only with the HUT firmware version packaged with the PIC32MZ1025W1, which is included in the MCHPRT3 tool package.

3. Testing and Calibration of PIC32MZ1025W1 with Wi-Fi Tester using MCHPRT3 Tool

This chapter provides details about using the MCHPRT3 tool to test or calibrate the PIC32MZ1025W1 with the Wi-Fi Tester. This chapter also demonstrates the process of updating the parameters using the MCHPRT3 tool. For more details, refer to the *PIC32MZ-W1 Regulatory Certification and Gain Table Application Note* (DS00004235).

3.1 MPLAB® X IPE HUT Code Programming Process with In-Circuit Serial Programming™ Header

In this demonstration, the user must program the PIC32MZ1025W1 with the HUT firmware using the PC with the MPLAB X IPE.

Note: The user must perform the HUT firmware programming before proceeding with the rest of the operation with the MCHPRT3 tool.

The In-Circuit Serial Programming (ICSP™) header (J206) is a standard six pin staggered header. The J206 allows in-circuit emulation, debugging using Microchip's in-circuit emulator tools and also allows direct programming of the WFI32E01 module. The ICSP header supports external debuggers, such as MPLAB PICKIT™ 4 and MPLAB Snap. Use the standard ICSP header to connect an MPLAB programmer or debugger to the PIC32 WFI32E Curiosity Board. The following figure illustrates the connection between the ICSP header, external debuggers and the PIC32 WFI32E Curiosity Board.

Figure 3-1. Connection Diagram of ICSP Connection for HUT Code Programming

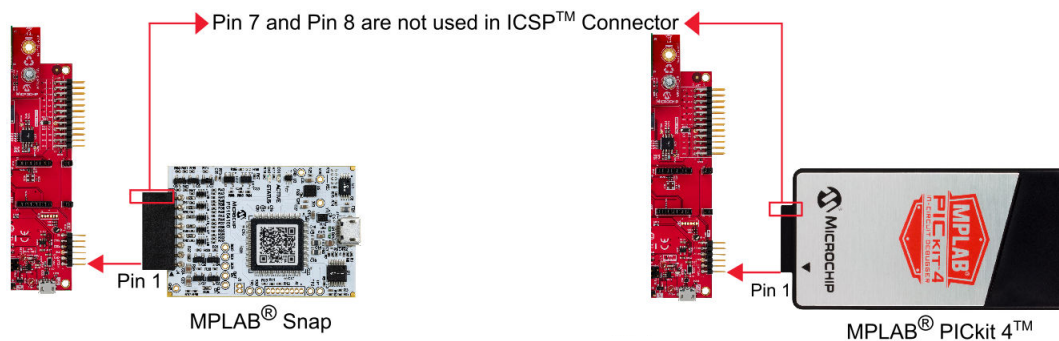

The following figure illustrates the start-up window of the MPLAB X IPE tool. Perform the following steps to set up the HUT firmware programming:

1. Set up the connection between the PIC32 WFI32E Curiosity Board and PC. For more details, refer to [3.2. Getting Started with MCHPRT3 Tool GUI for PIC32MZ1025W1](#).
2. Start the MPLAB X IPE tool, and select *PIC32MZ1025W104132* from the "Device" field.
3. Click **Connect** to connect the PIC32 WFI32E Curiosity Board to the MPLAB X IPE tool for the HUT firmware programming. If the device name is not available, check the USB connection (step 1).
4. Click **Browse** to load the HUT firmware HEX file (see [Table 2-2](#)).

Figure 3-2. Start-Up Window of the MPLAB X IPE Tool

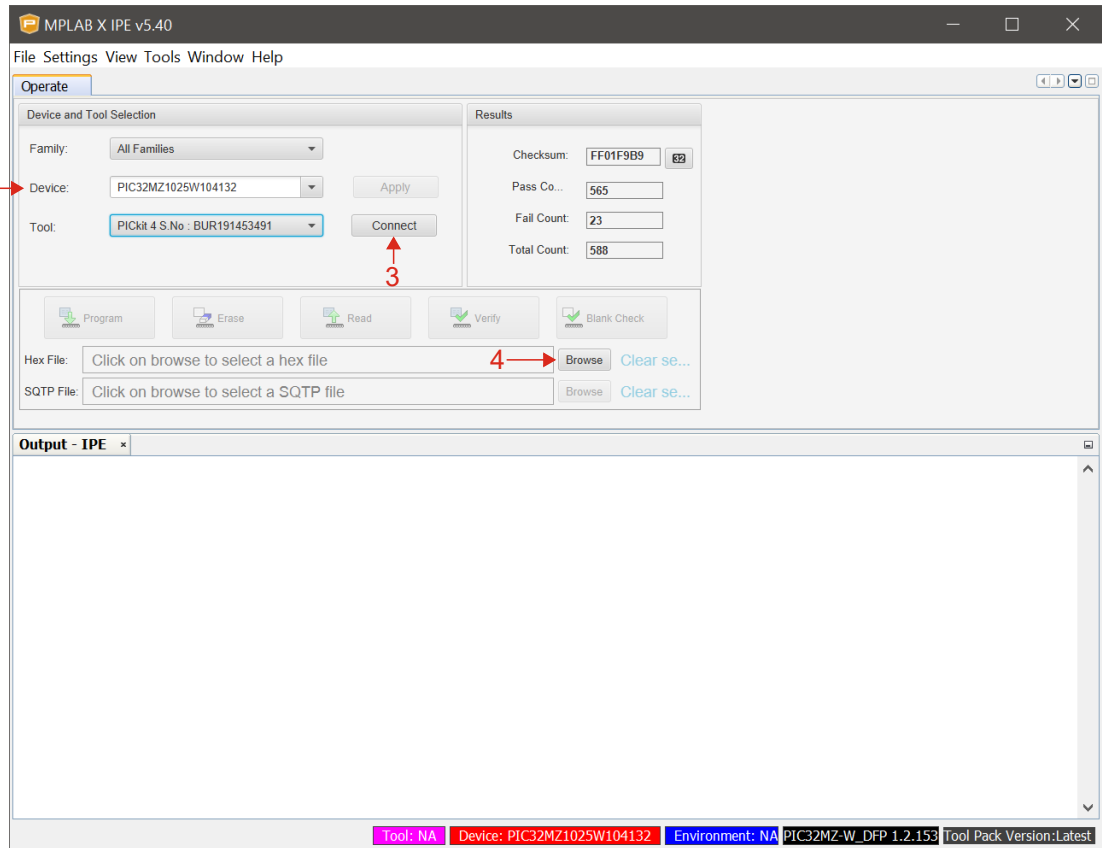

5. Click **Program**
6. After the completion of the HUT firmware programming, click **Disconnect** to disconnect the PIC32 WFI32E Curiosity Board and MPLAB X IPE tool (see the following figure).

Figure 3-3. MPLAB X IPE – Programming Complete

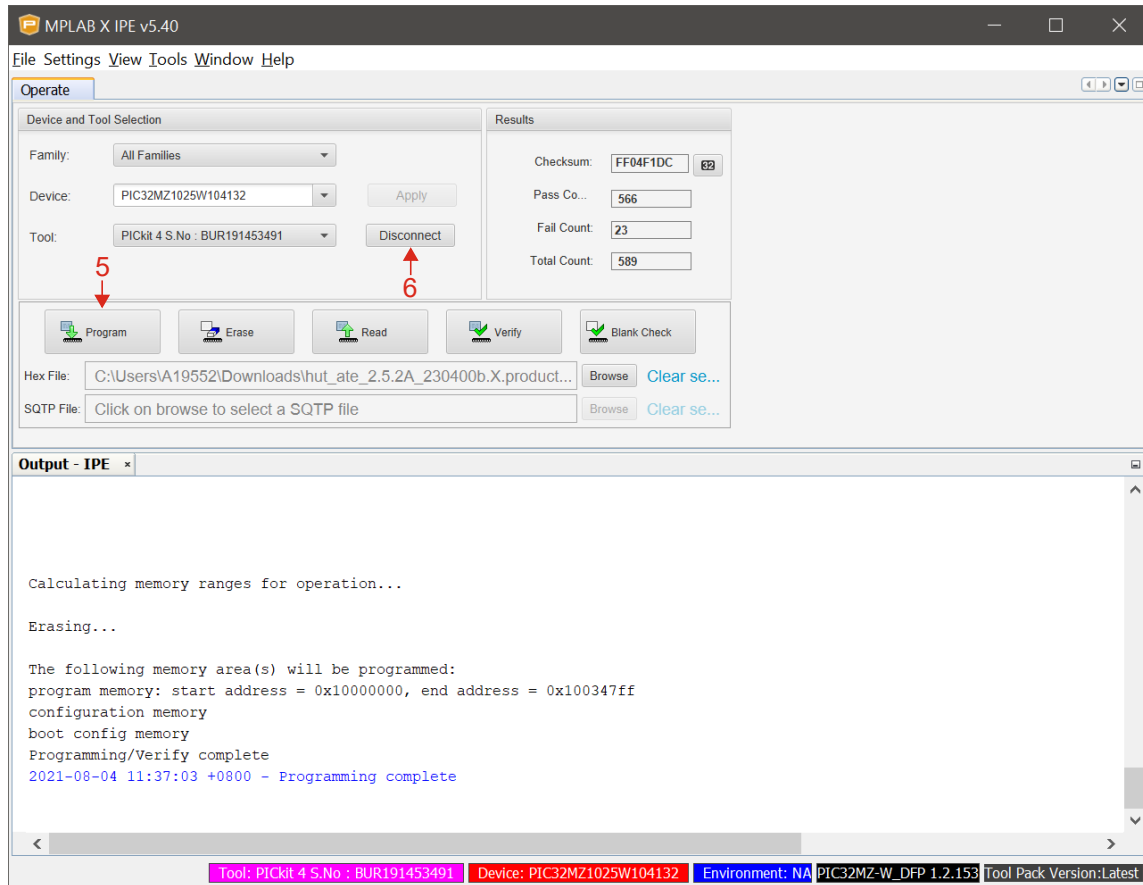

Disconnect external debuggers (MPLAB PICKIT 4 or MPLAB Snap) and Reset PIC32 WFI32E Curiosity Board for the RF test using the MCHPRT3 tool.

3.2 Getting Started with MCHPRT3 Tool GUI for PIC32MZ1025W1

The following block diagram illustrates the basic structure of the MCHPRT3 tool.

Figure 3-4. MCHPRT3 Tool Block Diagram

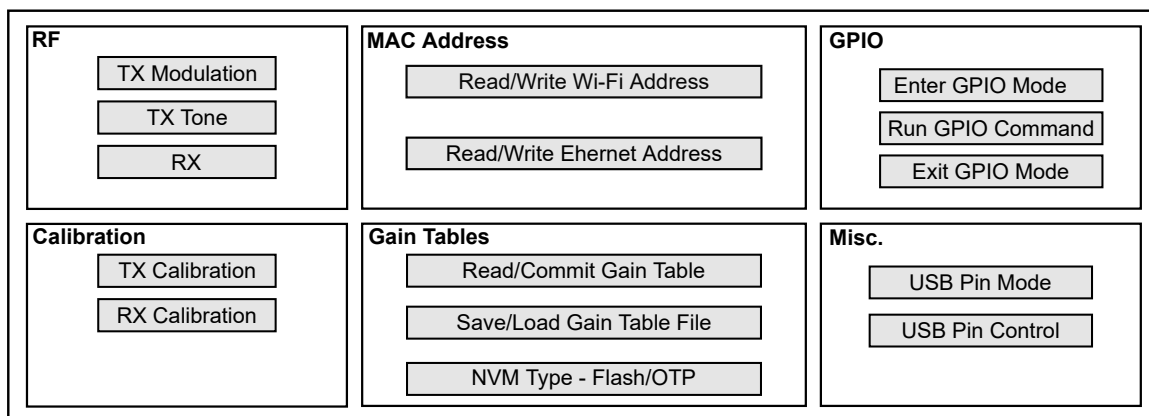

The following are the steps to launch the MCHPRT3 tool:

1. Double click the MCHPRT3 .exe file to launch the MCHPRT3 tool.
2. From the “Select GUI” drop-down list, select **PIC32MZ1025W1**.
3. Click **Open** to launch the PIC32MZ1025W1 window (see the following figure).

Figure 3-5. Start-Up Window of the MCHPRT3 Tool

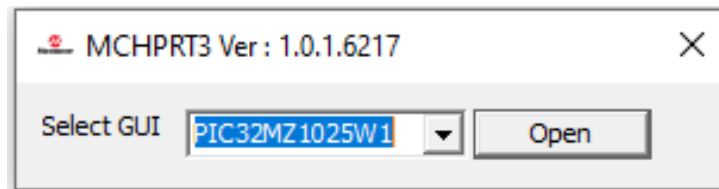

4. The PIC32MZ1025W1 window is divided into the following sections (see the following figure):
 - “DLL Version” – Dynamic Link Library (DLL) information and HUT firmware version supported by the MCHPRT3 tool
 - “COM Port” – Lists the available COM ports for the configuration
 - “Baud Rate” – By default, the MCHPRT3 tool configures the supported baud rate of the specific HUT firmware
Note: User cannot change the baud rate.
 - **Get FW Version** – Current firmware version is read from Device Under Test (DUT)
 - **Get Remaining OTP Size** – Remaining OTP size read from DUT
 - **RF** tab – Provides settings to perform the RF TX Modulation test (see [Figure 3-14](#))
 - **TX Modulation** tab – Provides settings to perform the TX modulation test (see [Figure 3-14](#))
 - **TX Tone** tab – Provides settings to perform the TX tone test (see [Figure 3-16](#))
 - **RX** tab – Provides settings to perform the RX test (see [Figure 3-17](#))
 - **Calibration** tab – Provides settings to perform TX and RX Calibration flow. The user can save the Calibration Info to a file or commit to NVM Type to Flash or OTP (see [Figure 3-19](#)).
 - TX Calibration – Provides settings to perform TX Calibration flow to adjust the transmitted power to the target
 - RX Calibration – Provides settings to perform RX Calibration flow to obtain the Received Signal Strength Indicator (RSSI) to its corresponding received power
 - **MAC Address** tab – Read/Write MAC address (see [Figure 3-20](#))
 - Read Wi-Fi address
 - Write Wi-Fi address
 - Read Ethernet address
 - Write Ethernet address
 - **Gain Tables** tab – Provides settings of Page Index, NVM Type and RF Version (see [Figure 3-23](#))
 - Read Gain Table – Reads the gain table from the selected Page Index and NVM Type
 - Commit Gain Table – Commits the gain table to selected Page Index and NVM Type
 - Apply Gain Table – Applies the gain table from the selected Page Index and NVM Type so that the transmission uses this for default gain values after the power cycle
 - Save Gain Table To File – Saves the gain table in a file and modifies the file if necessary
 - Load Gain Table From File – Loads the gain table from a file and commits or applies the gain table if necessary

- **GPIO** tab – Provides settings to test GPIO for the selected Port with a specified Pin, In/Out and Level (see [Figure 3-24](#))
 - Enter GPIO Mode – Initializes the GPIO for test
 - Run GPIO Command – Executes the GPIO test command for a selected Port with a specified Pin, In/Out and Level
 - Exit GPIO Mode – Stops the GPIO test and quits
- **Misc.** tab – Provides settings to test the USB Pin (see [Figure 3-25](#) and [Figure 3-26](#))
 - USB Pin Mode – Provides settings for Mode0 or Mode1
 - USB Pin Control – Executes USB Pin Mode

Figure 3-6. Start-Up Window of the PIC32MZ1025W1 GUI Tool

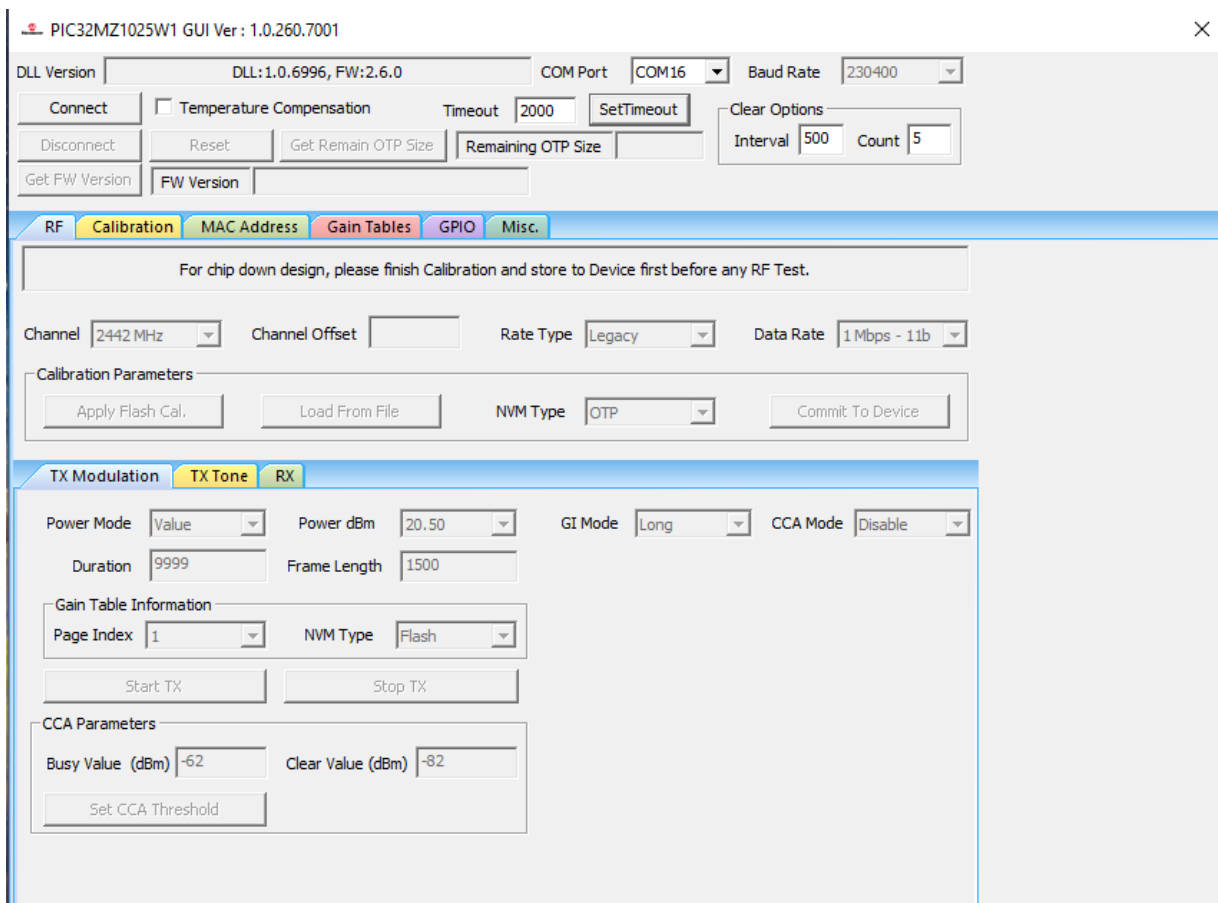

3.3 Performing RF Test on the PIC32 WFI32E Curiosity Board with MCHPRT3 Tool

The following are the steps to run the RF test on the PIC32 WFI32E Curiosity Board:

1. Flash the HUT firmware to the PIC32MZ1025W1. For more details, refer to [3.1. MPLAB X IPE HUT Code Programming Process with In-Circuit Serial Programming Header](#).
2. Connect the PIC32 WFI32E Curiosity Board UART to the PC with the MCHPRT3 tool (see the following figure).
3. Perform the following steps to set up a connection between the MCP2200 Breakout module and the PIC32 WFI32E Curiosity Board (see the following figure):
 - a. Connect pin1 to RX.

- b. Connect pin3 to ground (GND).
- c. Connect pin6 to TX.

Notes:

- The user can choose their own USB-to-UART serial converter.
- The MCP2200 Breakout module part number is ADM00393.

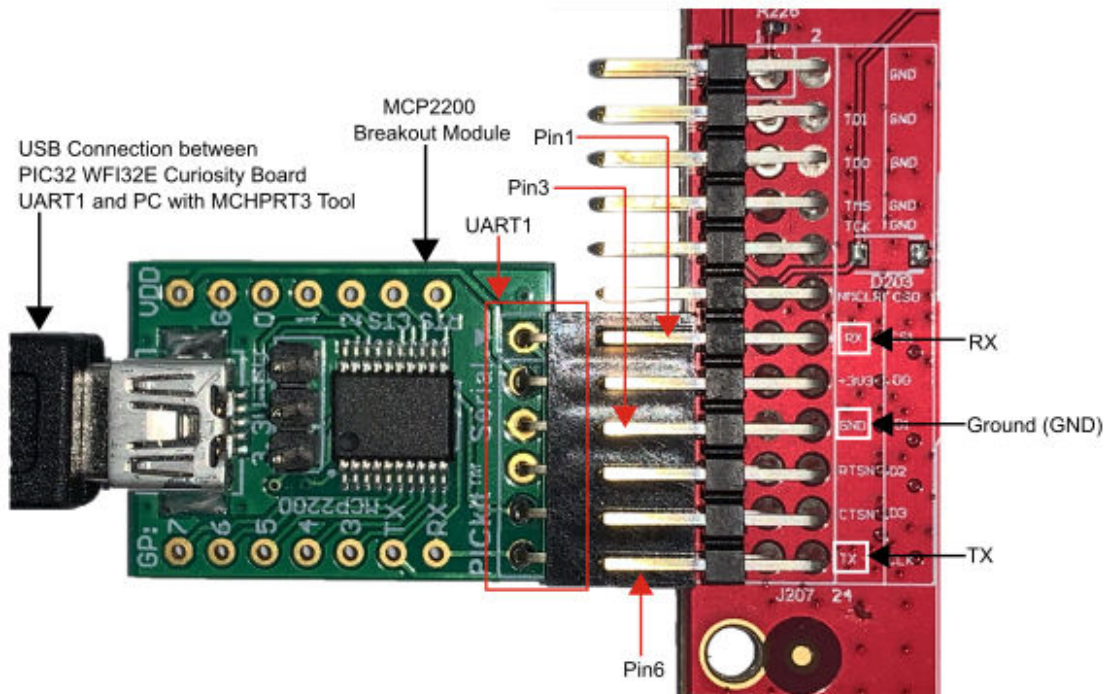
Figure 3-7. PIC32 WFI32E Curiosity Board U1TX, U1RX and GND Connection**Table 3-1.** PIC32 WFI32E Curiosity Board U1TX, U1RX and GND Connection

MCP2200 Breakout Module J5 Pin Name	MCP2200 Breakout Module J5 Pin Number	PIC32 WFI32E Curiosity Board J207 Pin Number	PIC32 WFI32E Curiosity Board J207 Pin Name
TX	1	13	U1RX
VDD	2	15	+3V3
GND	3	17	GND
CTS	4	19	RTS
RTS	5	21	CTS
RX	6	23	U1TX

4. Configure J202 at the PKOB position with the jumper, and connect the USB power to J302 USB micro B DEBUG on the PIC32 WFI32E Curiosity Board. This enables the WFI32E W1 module to work in the Debug/Test mode (see the following figure). For more details, refer to the *PIC32 WFI32E Curiosity Board User's Guide (DS50003028)*.

Figure 3-8. Power Tree Diagram

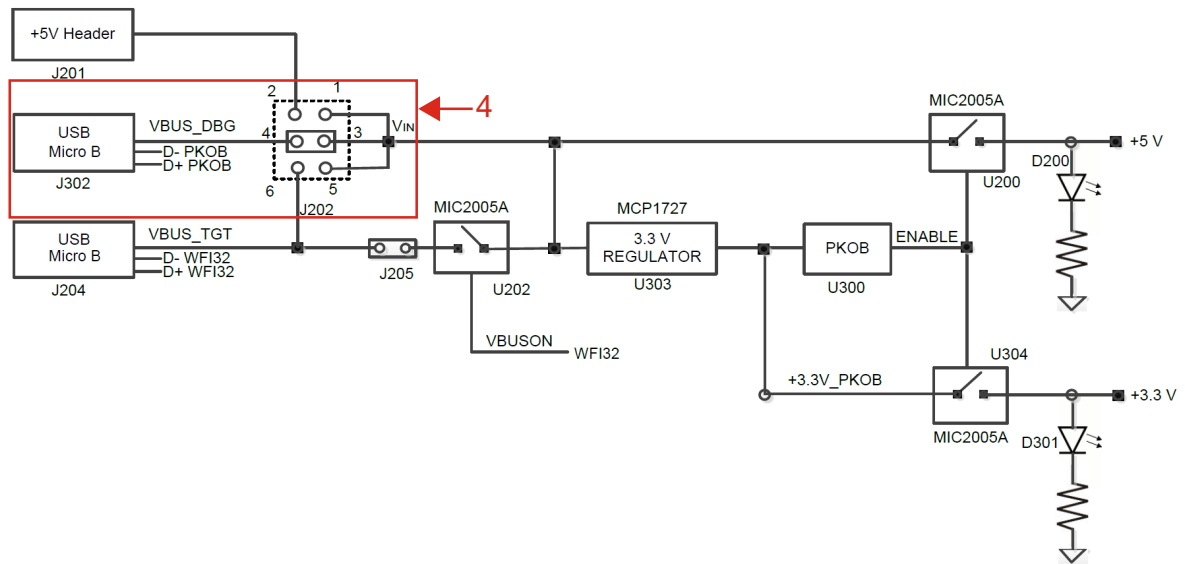

5. Perform the following steps for the demonstration of the RF test on the PIC32 WFI32E Curiosity Board with the MCHPRT3 tool (see [Figure 3-12](#)):
 - a. To run the MCHPRT3 tool, double click the `MCHPRT3.exe` file.
 - b. From the “Select GUI” drop-down list, select `PIC32MZ1025W1` (see [Figure 3-5](#)).
 - c. Choose the respective “COM port” from the drop-down list.
Note: Install the corresponding driver for the respective USB-to-UART serial converter.
 - d. Set the “Baud Rate” value to its default value.
 - e. Enter the “Timeout” value as `2000` (default value), and click **SetTimeout**.
Note: This value must be greater than 2000 milliseconds.
 - f. In the Clear Options area, enter the “Interval” value as `500` (default value) and “Count” as `5` (default value) for the UART command buffer time and retry.
 - g. Check the *Temperature Compensation* field if the test temperature is not at room temperature. By default, the *Temperature Compensation* is disabled.
 - h. Click **Connect** to connect the UART of the PIC32MZ1025W1 to the MCHPRT3 tool for the RF test (see the following figure).

Figure 3-9. Connect Device

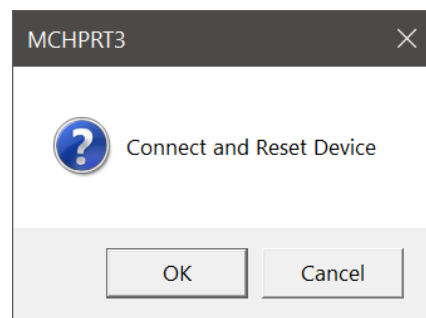

- i. Click **Get FW Version** and click **OK** in the pop-up window to reset the PIC32MZ1025W1 device. The firmware version appears instantly (see the following figure).

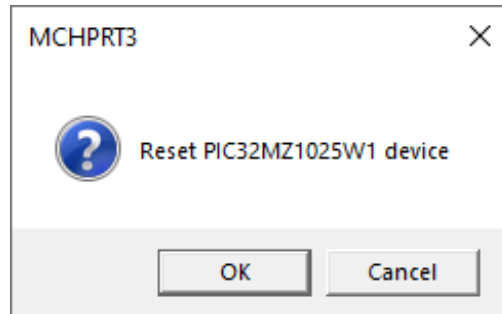
Figure 3-10. Reset PIC32MZ1025W1 Device

- j. Click **Get Remain OTP Size** to get the remaining OTP size in the device (see the following figure).

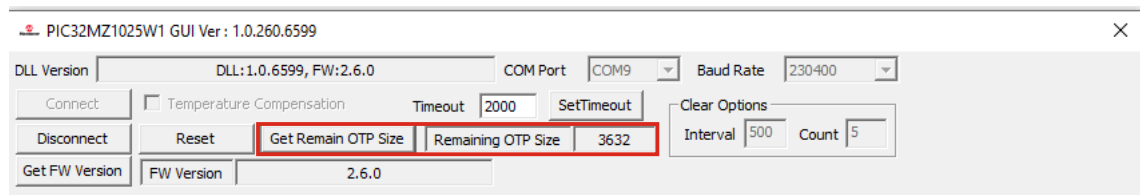
Figure 3-11. Get Remain OTP Size

- k. Click **Reset** to reset the device. The PIC32 WFI32E Curiosity Board is ready for RF Test, Calibration, MAC Address Programming, Gain Tables Editing and GPIO Test.
- l. Click **Disconnect** to quit the MCHPRT3 tool.

Figure 3-12. RF Test on PIC32 WFI32E Curiosity Board with MCHPRT3 Tool

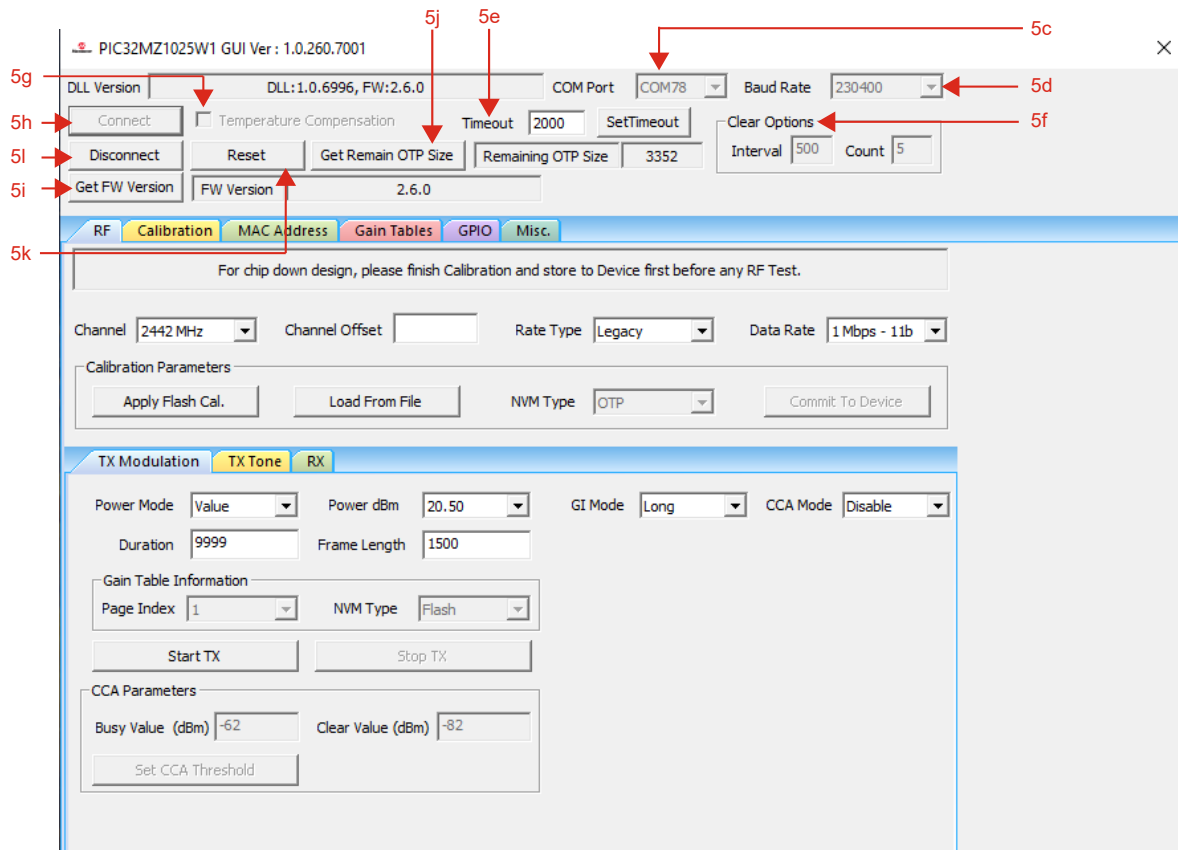

3.4 MCHPRT3 Tool with PIC32MZ1025W1 GUI Demonstration

3.4.1 RF TX Modulation Test Demonstration

In this demonstration, the user can transmit Wi-Fi standard packets with the PIC32MZ1025W1.

Perform the following steps for the demonstration of the RF TX modulation test:

1. Set up the connection between the PIC32 WFI32E Curiosity Board and PC. For more details, refer to [3.2. Getting Started with MCHPRT3 Tool GUI for PIC32MZ1025W1](#).
2. In the **RF** tab, perform the following steps (see [Figure 3-14](#)):
 - a. From the “Channel” drop-down list, select *2442 MHz* for channel 7.
 - b. By default, the “Channel Offset” value is left blank, but the channel offset uses the value from the WFI32E01 module. Enter a value ranging from -20 to 20 in the “Channel Offset” field. For example, enter *1* to add one gain step of 0.25 dB for the testing channel.
Note: If the “Channel Offset” value is left blank, it means the value can be zero and non-zero depending on the testing channel.
 - c. From the “Rate Type” drop-down list, select *Legacy* for 11b and 11g mode or *MCS* for 11n mode.
 - d. From the “Data Rate” drop-down list, select *1 Mbps - 11b* for 11b mode and 1 Mbps.
 - e. **Click Load From File** – to load the Calibration file (.cfg file), select NVM Type, then click **Commit To Device** if necessary.
 - f. If the Calibration file is loaded and committed to Flash, click **Apply Flash Cal.** to apply the Calibration parameters in Flash but not OTP.

3. In the **TX Modulation** tab, perform the following steps (see [Figure 3-14](#)):
 - a. On the “Power Mode” drop-down list, there are four options available:
 - *Value* – To configure the TX power manually in dBm scale. TX Power range is 10-25 dBm with 0.25 dB per step. The default value is 20.5 dBm. The recommendation is to use this option for validation, which does not require TPC.
 - *Index* – This option is similar to *Value* power mode, but values are configured in the index scale of 0-255.
 - *TPC Once* – This option reads gain values from the gain table from the selected NVM Type, and the TPC (Transmit Power Control) algorithm reads the operating voltage and the temperature and adjusts the TX power level settings once to compensate before the transmission.

Note: Any further change in the operating voltage/temperature will not be read by the TPC algorithm, so the TX power level will not vary with respect to operating voltage and temperature changes.
 - *TPC Auto* – This option reads gain values from the gain table from the selected NVM Type and applies the TPC algorithm, which maintains the stable TX power across temperature and operating voltage. The TPC algorithm will be active throughout the operation, so any changes in the operating voltage/temperature will read and compensate for the TX power level settings.
 - From the “Power Mode” drop-down list, select *TPC Once* or *TPC Auto* to read values from the gain table for the transmission (see [Figure 3-23](#)).
 - Read voltage and temperature and changing TX setting
 - *TPC Once* – One time before transmission
 - *TPC Auto* – Active throughout the operation
 - By default, “NVM Type” is *Flash* and “Page Index” is 1.
 - To change Gain Table Information. In the **Gain Table** tab, click **Read Gain Table** or **Commit Gain Table** (see [Figure 3-23](#)).

Figure 3-13. Power Mode Selection

PIC32MZ1025W1 GUI Ver : 1.0.260.7001

DLL Version: DLL:1.0.6996, FW:2.6.0 COM Port: COM78 Baud Rate: 230400

Connect Temperature Compensation Timeout: 2000 SetTimeout Clear Options

Disconnect Reset Get Remain OTP Size Remaining OTP Size: 3352 Interval: 500 Count: 5

Get FW Version FW Version: 2.6.0

RF Calibration MAC Address Gain Tables GPIO Misc.

For chip down design, please finish Calibration and store to Device first before any RF Test.

Channel: 2442 MHz Channel Offset: Rate Type: Legacy Data Rate: 1 Mbps - 11b

Calibration Parameters

Apply Flash Cal. Load From File NVM Type: OTP Commit To Device

TX Modulation TX Tone RX

Power Mode: Value Power dBm: 20.50 GI Mode: Long CCA Mode: Disable

Index

Duration: TPC Auto Frame Length: 1500

Gain Table Index: Value

Page Index: 1 NVM Type: Flash

Start TX Stop TX

CCA Parameters

Busy Value (dBm): -62 Clear Value (dBm): -82

Set CCA Threshold

- b. Retain the “Duration” as 9999 (default value).
- c. Retain the “Frame Length” as 1500 (default value).
- d. From the “GI Mode” drop-down list, select *Long* for long GI and *Short* for short GI.
- e. Retain the “CCA Mode” as *Disable* (default value). If the “CCA Mode” is set as *Enable*, perform the following steps:
 - Enter the “Busy Value (dBm)”. Default value is -62.
 - Enter the “Clear Value (dBm)”. Default value is -82.
 - Click **Set CCA Threshold** to change the CCA threshold value if required.
- f. Click **Start TX** to transmit Wi-Fi packets as configured in step 2 and step 3. Use the Wi-Fi tester to verify the transmitting packets.
- g. Click **Stop TX** to stop the transmission.

Figure 3-14. MCHPRT3 PIC32MZ1025W1 GUI for RF TX Modulation Test Demonstration

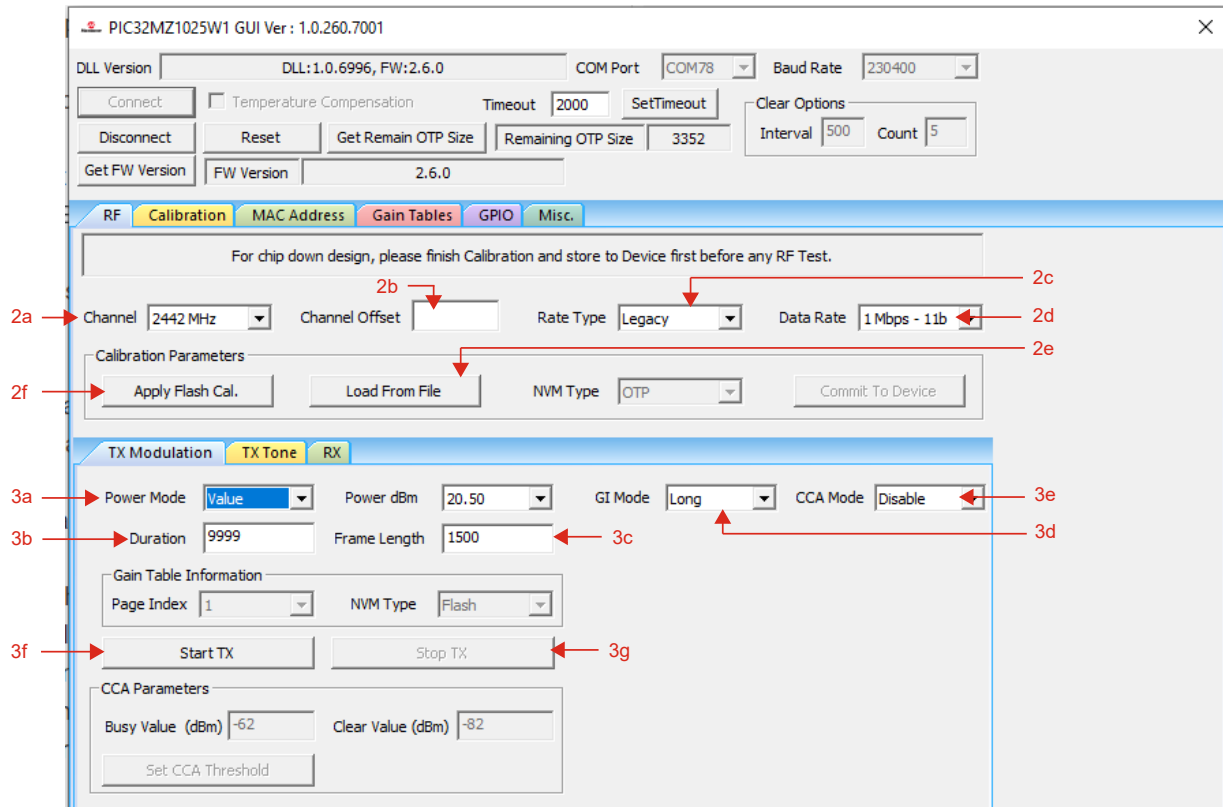

3.4.2 RF TX Tone Test Demonstration

In this demonstration, the user can transmit a single tone on the PIC32MZ1025W1.

Perform the following steps for the demonstration of the transmission:

1. Set up the connection between the PIC32 WFI32E Curiosity Board and PC. For more details, refer to [3.2. Getting Started with MCHPRT3 Tool GUI for PIC32MZ1025W1](#).
2. In the **RF** tab, from the "Channel" drop-down list, select *2442 MHz* for channel 7 (see the following figure).
3. In the **TX Tone** tab, perform the following steps:
 - From the "Power Mode" drop-down list (see the following figure).
 - Select *Value* for output power in dBm.
 - Select *Index* for manual input gain index.
 - Enter the "Power dBm" value from 10-25 dBm, each step equals 0.25 dB. 20.5 dBm is the default value.

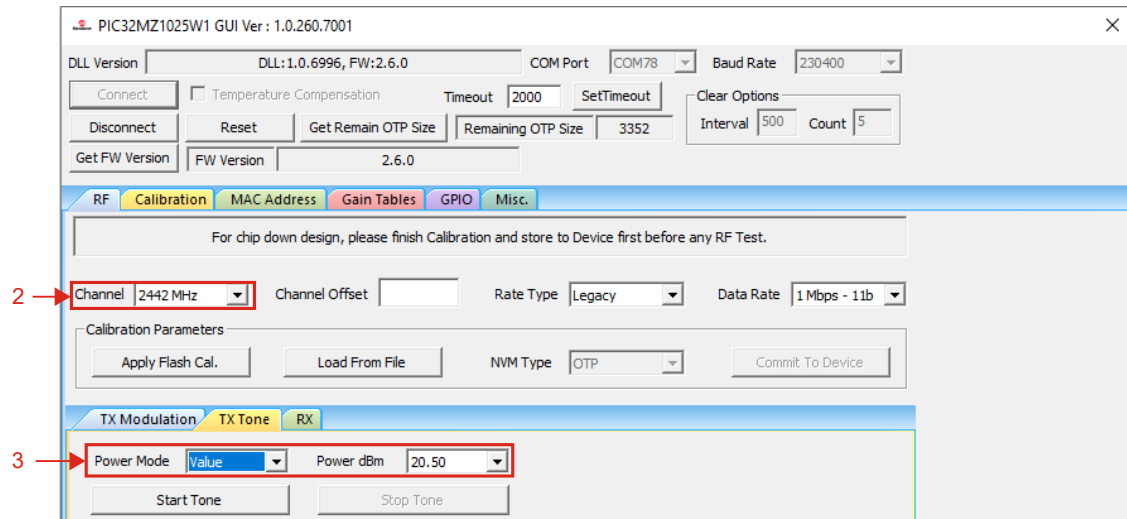
Figure 3-15. TX Tone Power Mode Value

- Enter the “Gain Index” value from 0-255, 0.25 dB per step (see the following figure).

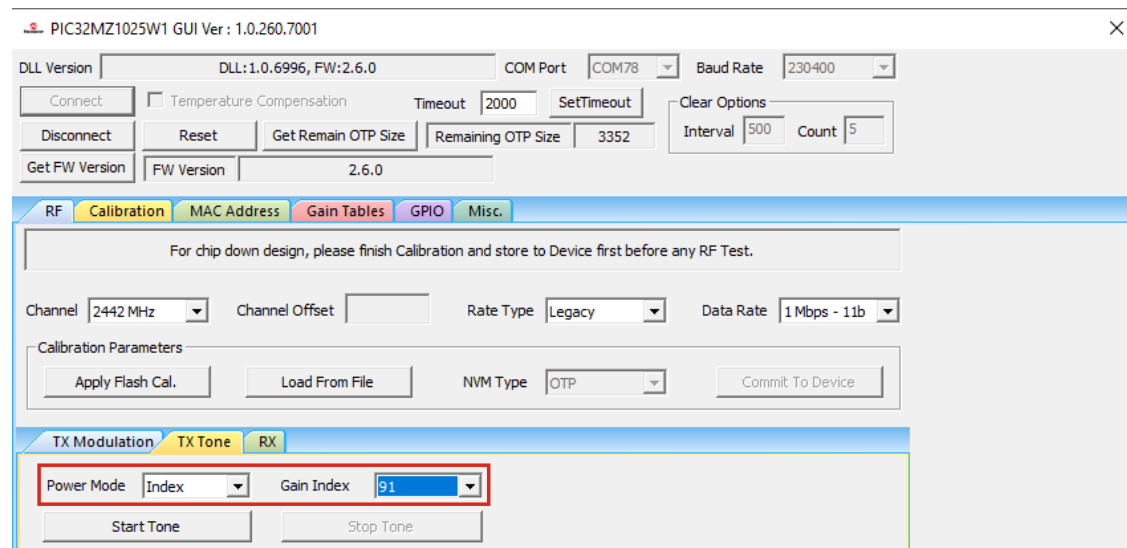
Figure 3-16. TX Tone Power Mode Gain Index

- Click **Start Tone** to transmit a single tone as configured in step 2 and step 3. Use Spectrum Analyzer to verify the transmitting single tone.
- Click **Stop Tone** to stop the transmission.

3.4.3 RF RX Test Demonstration

In this demonstration, the user can receive Wi-Fi packets on the PIC32MZ1025W1.

Perform the following steps for the receiving demonstration.

1. Set up the connection between the PIC32 WFI32E Curiosity Board and PC. For more details, refer to [3.2. Getting Started with MCHPRT3 Tool GUI for PIC32MZ1025W1](#).
2. In the **RF** tab, perform the following steps (see the following figure):
 - a. From the “Channel” drop-down list, select *2442 MHz* for channel 7.

- b. From the “Rate Type” drop-down list, select *Legacy* for 11b and 11g mode, *MCS* for 11n mode or *ALL – RX Only* for all data rates.
 - c. From the “Data Rate” drop-down list, select *1 Mbps – 11b* for 11b mode and 1 Mbps.
3. In the **RX** tab, perform the following steps (see the following figure):
 - a. Click **Start RX** to receive Wi-Fi packets as configured in step 2. Use the IQxel Wi-Fi tester or other tools to send the Wi-Fi packets to the PIC32 WFI32E Curiosity Board.
 - b. Click **Stop RX** to stop receiving the Wi-Fi packets.
 - c. Click **Get RX Count**. The “RX Count Information” table shows the received Wi-Fi packets.
 - d. Click **Clear RX Count** to Reset RX Count Information.
 - e. Repeat the above steps for a new RX test.
 - f. Click **Get RSSI** to read the RSSI value.

Figure 3-17. MCHPRT3 PIC32MZ1025W1 GUI for RF RX Test Demonstration

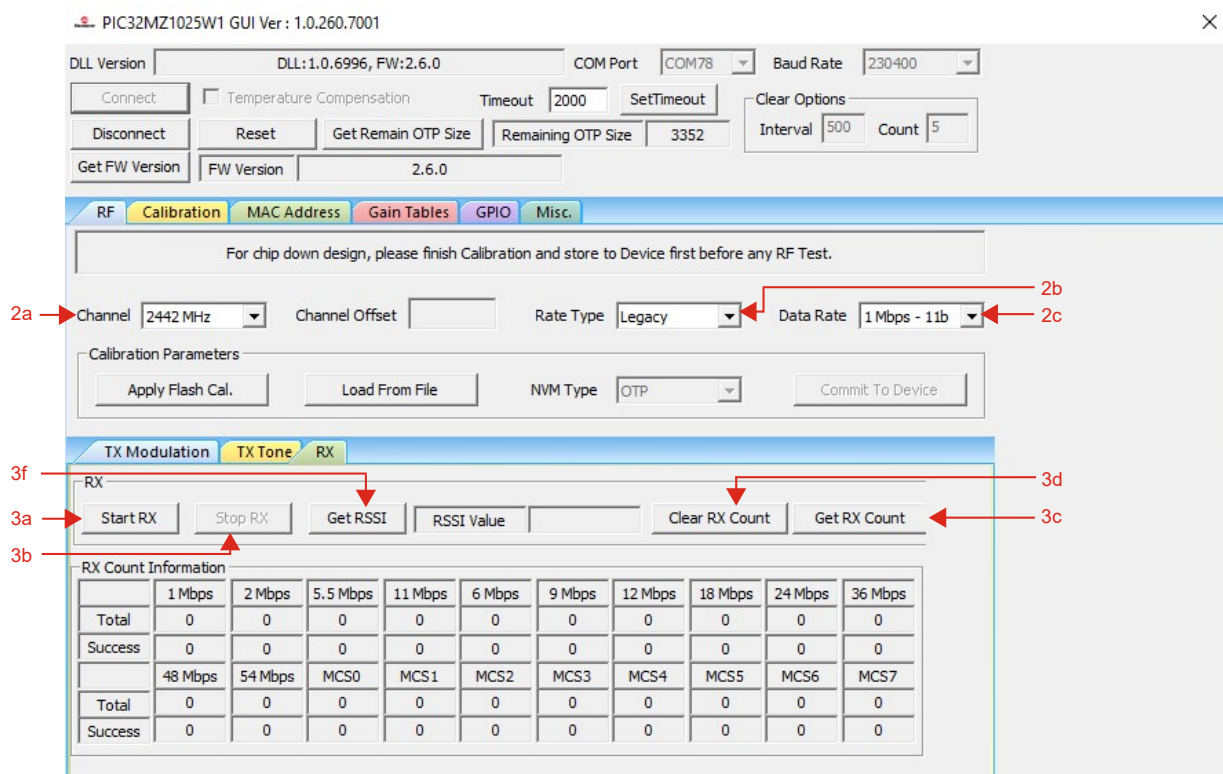

3.4.4 Calibration Flow Demonstration

In this demonstration, the user can Calibrate TX parameters and RX parameters of the PIC32MZ1025W1.

Perform the following steps for the demonstration of the Calibration flow (see the following figure):

1. Set up the connection between the PIC32 WFI32E Curiosity Board and PC. For more details, refer to [3.2. Getting Started with MCHPRT3 Tool GUI for PIC32MZ1025W1](#).
2. Connect the U.FL connector on the PIC32MZ1025W1 to the Wi-Fi tester (IQxel or other) to measure the RF power from the PIC32MZ1025W1

Note: For calibration, the conducted test setup is recommended.

3. Check the cable loss between the PIC32MZ1025W1 U.FL connector and the Wi-Fi tester. Enter the cable loss or RF power offset into the Wi-Fi tester.
4. Set the Wi-Fi tester to receive the Wi-Fi packets that are transmitted from the PIC32MZ1025W1.
5. In the **Calibration** tab, perform the following steps (see the following figure):
 - a. Click **Start TX Calibration** to start the new TX calibration.
 - b. Read the RF Power on the Wi-Fi tester. Enter the measured RF Power from the Wi-Fi tester in "1.1.1 Input Power".
 - c. If the power does not reach the target power (17.5 dBm +/- 0.25 dB), click **1.1.2 Coarse Tune**.
 - d. Read the RF Power on the Wi-Fi tester. Enter the measured RF Power from the Wi-Fi tester in "1.2.1 Input Power".
 - e. If the power does not reach the target power (17.5 dBm +/- 0.25 dB), click **1.2.2 First Fine Tune**.
 - f. Read the RF Power on the Wi-Fi tester. Enter the measured RF Power from the Wi-Fi tester in "1.3.1 Input Power".
 - g. If the power does not reach the target power (17.5 dBm +/- 0.25 dB), click **1.3.2 Second Fine Tune**.
 - h. Read the RF Power on the Wi-Fi tester. Enter the measured RF Power from the Wi-Fi tester in "1.4.1 Input Power".
 - i. If the power reaches the target power (17.5 dBm +/- 0.25 dB), click **1.4.2 Stop TX Calibration**.
Note: There is a possibility of three iterations on the TX Calibration. In any iteration, if the rule of 17.5+/-0.125 dB output power limit is satisfied, there is no need for further tuning. The user can skip the other iterations and go to **Stop TX Calibration** to finish the TX Calibration process.
6. Click **2.0 Start RX Calibration** to start the new RX calibration.
7. Check the cable loss between the PIC32MZ1025W1 U.FL connector and the Wi-Fi tester. Enter the cable loss or the RF power offset into the Wi-Fi tester.
8. Set the Wi-Fi tester to transmit Wi-Fi MCS7 packets at 2442 MHz and -45 dBm power level that will be received by PIC32MZ1025W1.
9. Click **2.1 Init Gain Flag**.
10. Click **2.2 Get Gain Flag (-45 dBm)**.
11. Set -20 dBm power level on the IQxel Wi-Fi tester (see the following figure).

Figure 3-18. IQxel -20 dBm

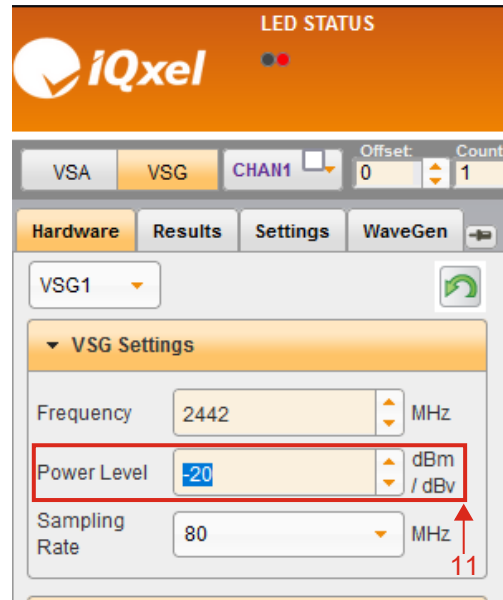

Note: The user can choose their own Wi-Fi tester tool. In this case, the IQxel Wi-Fi tester tool is shown only as an example. Change the "Power Level" setting for different scenarios in the following steps using the same IQxel Wi-Fi tester tool.

12. Click **2.3 Read RSSI (-20 dBm)**.
13. Set -35 dBm power level in the Wi-Fi tester.
14. Click **2.4 Read RSSI (-35 dBm)**.
15. Set -45 dBm power level in the Wi-Fi tester.
16. Click **2.5 Read RSSI (-45 dBm)**.
17. Set -50 dBm power level in the Wi-Fi tester.
18. Click **2.6 Read RSSI (-50 dBm)**.
19. Set -65 dBm power level in the Wi-Fi tester.
20. Click **2.7 Read RSSI (-65 dBm)**.
21. Click **2.8 Stop RX Calibration** to finish the RX Calibration.
22. Click **3. Save To File** to save the calibration parameters to file.
23. Click **4. Commit To Device** to write the calibration parameters to the device with respect to **NVM Type** Flash or OTP.

Figure 3-19. MCHPRT3 PIC32MZ1025W1 GUI for Calibration Flow Demonstration

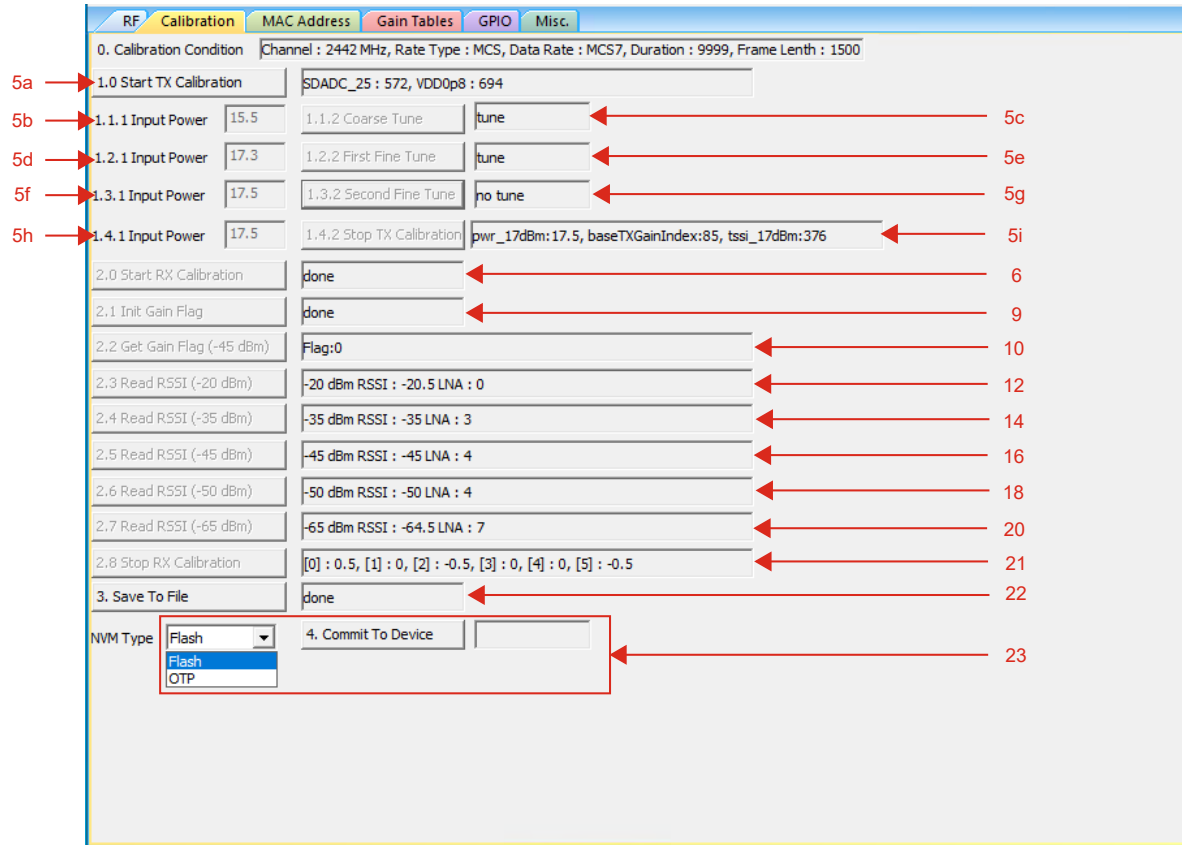

3.4.5 MAC Address Programming

In this demonstration, the user can set the MAC address of the Wi-Fi and Ethernet interfaces of the PIC32MZ1025W1.

In the **MAC Address** tab, perform the following steps for MAC Address programming:

1. Set up the connection between the PIC32 WFI32E Curiosity Board and PC. For more details, refer to [3.2. Getting Started with MCHPRT3 Tool GUI for PIC32MZ1025W1](#).
2. In the **MAC Address** tab, perform the following steps (see the following figure):
 - Click **Read Wifi Address** to read the Wi-Fi address.
 - Click **Write Wifi Address**, and enter the Wi-Fi address to write the Wi-Fi address, for example, *12:34:56:78:9A:BC*.
 - Click **Read Ethernet Address** to read the Ethernet address.
 - Click **Write Ethernet Address**, and enter the Ethernet address to Write Ethernet Address, for example, *12:34:56:78:9A:BC*.

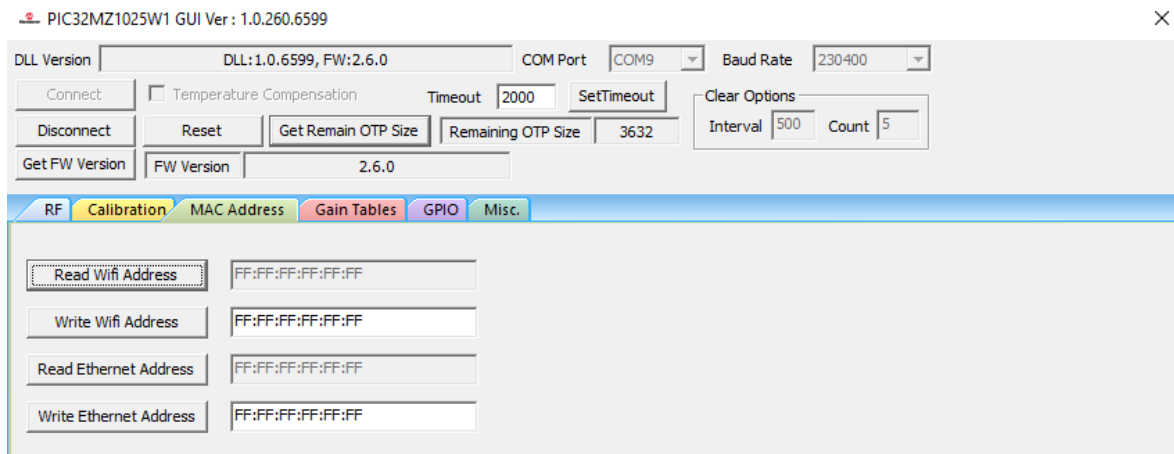
Figure 3-20. MCHPRT3 PIC32MZ1025W1 GUI for MAC Address Programming

3.4.6 Gain Tables Demonstration

In this demonstration, the user can edit the gain tables of the PIC32MZ1025W1. The gain tables are the power settings stored in “NVM Type” of the PIC32MZ1025W1, which is either *Flash* or *OTP* type to control the TX power in application firmware (see [Figure 3-22](#)). The “Page Index” value ranges from 1-6, and the user can store the gain tables information in the “Page Index” for the respective “NVM Type” either in the form of *Flash* or *OTP* type (see the following figure).

Perform the following steps for the Gain Tables demonstration.

1. Set up the connection between the PIC32 WFI32E Curiosity Board and PC. For more details, refer to [3.2. Getting Started with MCHPRT3 Tool GUI for PIC32MZ1025W1](#).
2. In the **Gain Tables** tab, perform the following steps (see [Figure 3-23](#)):
 - a. From the “Page Index” drop-down list, select the value ranging from 1-6 to read or write for the gain table (see the following figure).

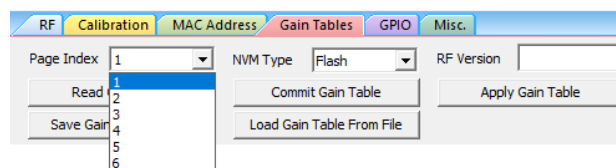
Figure 3-21. Gain Table Page Index

- b. From the “NVM Type” drop-down list, select either the *Flash* or *OTP* Type to read or write for the gain table (see the following figure).

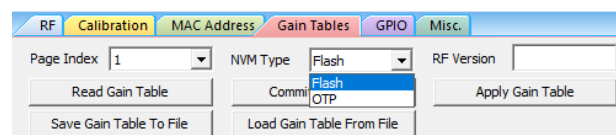
Figure 3-22. Gain Table NVM Type

- c. Click **Read Gain Table** to read the gain table. This will change the default Gain Table Information in **RF** Tab (see [Figure 3-13](#)).
 - d. Click **Save Gain Table To File** to save the gain table for backup and editing. The user can edit the saved gain table text file if the user needs to modify the gain settings.

- Click **Load Gain Table From File** to load the gain table into the “MCHPRT3” tool.
- Enter a value for “RF Version”, and click **Commit Gain Table** to commit and write the gain table into the device. This will change the default Gain Table Information in the **RF** tab (see [Figure 3-13](#)).
- Click **OK** in the pop-up window to write the gain table.

Figure 3-23. MCHPRT3 PIC32MZ1025W1 GUI for Gain Tables Demonstration

PIC32MZ1025W1 GUI Ver : 1.0.260.7001

DLL Version: DLL:1.0.6996, FW:2.6.0 COM Port: COM78 Baud Rate: 230400

Connect Temperature Compensation Timeout: 2000 SetTimeout Clear Options

Disconnect Reset Get Remain OTP Size Remaining OTP Size: 3352 Interval: 500 Count: 5

Get FW Version FW Version: 2.6.0

RF Calibration MAC Address **Gain Tables** GPIO Misc.

Page Index: 1 NVM Type: Flash RF Version: 1

2c → Read Gain Table Commit Gain Table ← 2f

2d → Save Gain Table To File Load Gain Table From File ← 2e

Table Format Version : 0;
 NVM Type : Flash;
 Page Index : 1;
 Country Code : IEEE;
 Operating Channels : 2412, 2417, 2422, 2427, 2432, 2437, 2442, 2447, 2452, 2457, 2462, 2467, 2472;
 Band Edge Channels : ;
 RF Version : 1;

Packet Type	Data Rate	Non Band Edge Power Target (dEm)	Band Edge Power Target (dEm)
11b.	1.	20.5	20.5
11b.	2.	20.5	20.5
11b.	5.5.	20.5	20.5
11b.	11.	20.5	20.5
11g.	6.	19.5	19.5
11g.	9.	19.5	19.5
11g.	12.	19.5	19.5
11g.	18.	19.5	19.5
11g.	24.	19.5	19.5
11g.	36.	19.5	19.5
11g.	48.	19.5	19.5
11g.	54.	18.5	18.5
11n.	MCS0.	18.5	18.5
11n.	MCS1.	18.5	18.5
11n.	MCS2.	18.5	18.5
11n.	MCS3.	18.5	18.5
11n.	MCS4.	18.5	18.5
11n.	MCS5.	18.5	18.5
11n.	MCS6.	18.	18.
11n.	MCS7.	17.	17.

3.4.7 GPIO Demonstration

In this demonstration, the user can configure or test the GPIO of the PIC32MZ1025W1.

In the **GPIO** tab, perform the following steps for GPIO Demonstration (see the following figure):

- Click **Enter GPIO Mode** to initiate the GPIO settings for configuration or test.
- Check “Item” for individual GPIO or “Select All” for multiple GPIOs.
 - “Item” – “Item 00”, “Item 01”, “Item 02” and more
- Select “Port”, “Pin”, “In/Out” and “Level” to configure or test the GPIO pins.
 - “Port” – *Port A*, *Port B* and *Port C*
 - “Pin” – *PA00*, *PB01*, *PC02* and more
 - “In/Out” – *INPUT* and *OUTPUT*
 - “Level” – *HIGH* and *LOW*
- Click **Run** for individual GPIO, or click **Run GPIO Command** for multiple GPIOs.

- Click **Exit GPIO Mode** to stop the GPIO settings.

Figure 3-24. MCHPRT3 PIC32MZ1025W1 GUI GPIO Demonstration

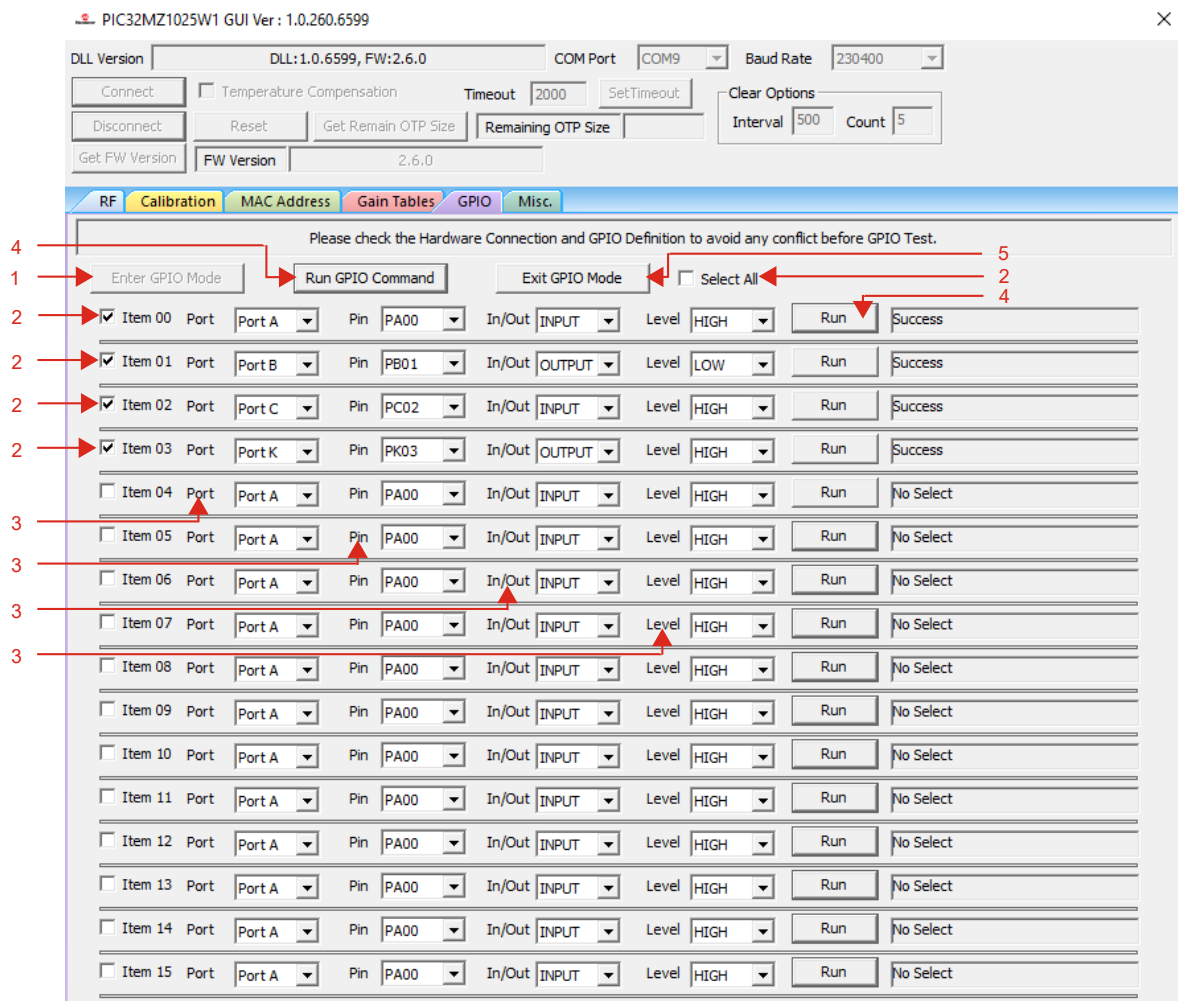

3.4.8 Misc. – USB Pin Control Demonstration

In this demonstration, the user can configure or test the USB pin of the PIC32MZ1025W1.

In the **Misc.** tab, perform the following steps for the USB Pin Control Demonstration (see the following figure):

- From the “USB Pin Mode” drop-down list, select *Mode0*.
- Click **USB Pin Control** to set *USB D+ pin* as logic low and *USB D- pin* as logic high.

Figure 3-25. Mode0 USB Pin Control

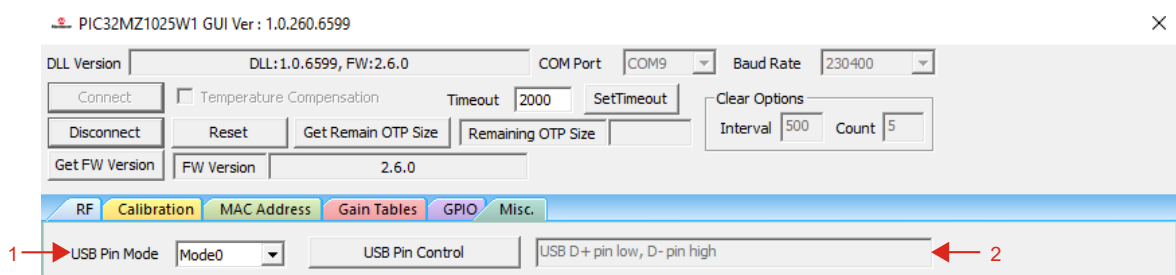

3. From the “USB Pin Mode” drop-down list, select *Mode1*.
4. Click **USB Pin Control** to set *USB D+ pin* as logic high and *USB D- pin* as logic low.

Figure 3-26. Mode1 USB Pin Control

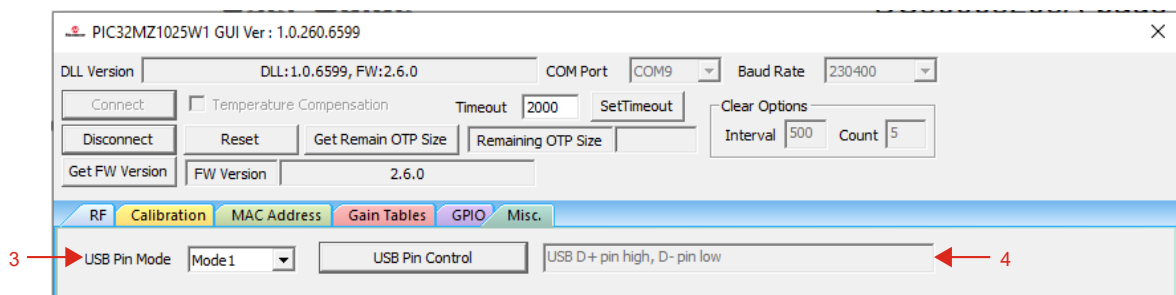

3.5 PIC32MZ1025W1 Dynamic Link Library (DLL) Gain Table Information

This section describes the PIC32MZ1025W1 gain table information and explains how to modify the gain table.

3.5.1 Gain Table Example

The PIC32MZ1025W1 gain table is a text-based file that the user can open or edit using any text editor. The following are the rules for a gain table file:

- “; ; ;” means comment entire line.
- If the first character is “;”, this row is for file information.
Note: The user must not modify this row.
- If the first character is blank, means this row has the Gain Table information. The user can modify the power target values but not other information and format.
 - Gain table information power target values range from 10-25 dBm; each step equals 0.25 dB.

Note: If any of the information in the gain table is not available, this group of information is invalid.

Figure 3-27. PIC32MZ1025W1 Gain Table

```

gain_table_20230529_163249.txt - Notepad
File Edit Format View Help
|;;=====
|;; PIC32MZ1025W1 DLL Gain Tables Information;
|;Save File Date      : 2023/05/29 16:33:06
|;Save DLL Version    : 1.0.6599, Support HUT Version : 2.6.0
|;File Format Version : 0
|;;=====
|;;
|;;*****
|;;
|Table Format Version : 0;
|NVM Type           : Flash;
|Page Index         : 1;
|Country Code       : IEEEE;
|Operating Channels : 2412, 2417, 2422, 2427, 2432, 2437, 2442, 2447, 2452, 2457, 2462, 2467, 2472;
|Band Edge Channels : ;
|RF Version         : 1;
|;;
|;;+-----+-----+-----+-----+
|;;| Packet Type | Data Rate | Non Band Edge | Band Edge |
|;;|            |           | Power Target (dBm) | Power Target (dBm) |
|;;+-----+-----+-----+-----+
|;;
|;;      11b,      1,      20.5,      20.5,      ;
|;;      11b,      2,      20.5,      20.5,      ;
|;;      11b,      5.5,      20.5,      20.5,      ;
|;;      11b,      11,      20.5,      20.5,      ;
|;;-----
|;;      11g,      6,      19.5,      19.5,      ;
|;;      11g,      9,      19.5,      19.5,      ;
|;;      11g,      12,      19.5,      19.5,      ;
|;;      11g,      18,      19.5,      19.5,      ;
|;;      11g,      24,      19.5,      19.5,      ;
|;;      11g,      36,      19.5,      19.5,      ;
|;;      11g,      48,      19.5,      19.5,      ;
|;;      11g,      54,      18.5,      18.5,      ;
|;;-----
|;;      11n,      MCS0,      18.5,      18.5,      ;
|;;      11n,      MCS1,      18.5,      18.5,      ;
|;;      11n,      MCS2,      18.5,      18.5,      ;
|;;      11n,      MCS3,      18.5,      18.5,      ;
|;;      11n,      MCS4,      18.5,      18.5,      ;
|;;      11n,      MCS5,      18.5,      18.5,      ;
|;;      11n,      MCS6,      18,      18,      ;
|;;      11n,      MCS7,      17,      17,      ;
|;;-----
|;;

```

3.6 PIC32MZ1025W1 Command Line Interface (CLI) Information

The section describes the Command Line Interface (CLI) information of the PIC32MZ1025W1.

3.6.1 PIC32MZ1025W1 CLI Example

The PIC32MZ1025W1 CLI is a part of the MCHPRT3 tool installer.

1. Double click MCHPRT3_CLI.exe to run the CLI.

Figure 3-28. MCHPRT3_CLI.exe

```

C:\Microchip\MCHPRT3_Setup_v1.0.2.7128\MCHPRT3_CLI.exe
*****
MCHPRT3_CLI Ver:1.0.1.7121
-----
Usage :
    ">Device" to list support device
    ">Exit" to exit MCHPRT3_CLI
-----
Support device :
                PIC32MZ1025W1
*****
>

```

2. To test the PIC32MZ1025W1, enter PIC32MZ1025W1.

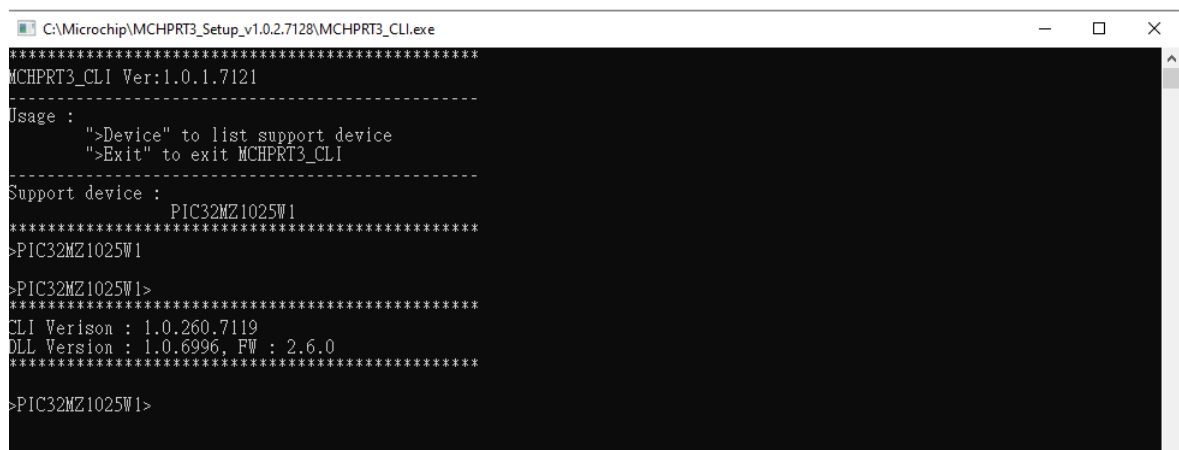
Figure 3-29. Device Testing – PIC32MZ1025W1

```

C:\Microchip\MCHPRT3_Setup_v1.0.2.7128\MCHPRT3_CLI.exe
*****
MCHPRT3_CLI Ver:1.0.1.7121
-----
Usage :
    ">Device" to list support device
    ">Exit" to exit MCHPRT3_CLI
-----
Support device :
                PIC32MZ1025W1
*****
>PIC32MZ1025W1
>PIC32MZ1025W1>
*****
CLI Verison : 1.0.260.7119
DLL Version : 1.0.6996, FW : 2.6.0
*****
>PIC32MZ1025W1>

```

3. Enter help to browse the CLI help manual.

Figure 3-30. CLI help Manual

```

C:\Microchip\MCHPRT3_Setup_v1.0.2.7128\MCHPRT3_CLI.exe
*****
MCHPRT3_CLI Ver:1.0.1.7121
-----
Usage :
  ">Device" to list support device
  ">Exit" to exit MCHPRT3_CLI
-----
Support device :
  PIC32MZ1025W1
*****
>PIC32MZ1025W1
>PIC32MZ1025W1>
*****
CLI Verison : 1.0.260.7119
DLL Version : 1.0.6996, FW : 2.6.0
*****
>PIC32MZ1025W1>help
Help Success
*****
PIC32MZ1025W1_CLI Ver:1.0.260.7119
-----
 1. ListCOMPort : List COM Port
 2. CLI_Version : Show CLI Version
 3. GetDllVersion : Get DLL version and support FW version
 4. Connect : Connect device
 5. Disconnect : Disconnect device
 6. SetTimeout : Set command timeout time (ms)
 7. Reset : Reset device
 8. ReadFwVersion : Read device FW version
 9. ReadRemainingOTPSize : Read remaining OTP Size
10. ApplyFlashCal : Apply Flash Calibration
11. LoadCalParamsFile : Load Calibration Parameters File
12. CommitCalParams : Commit Calibration Parameters
13. StartTx : Start TX
14. StopTx : Stop TX
15. SetCcaThresholds : Set CCA thresholds
16. StartTone : Start Tone
17. StopTone : Stop Tone
18. StartRx : Start RX
19. StopRx : Stop RX
20. ReadRssi : Read RSSI
21. ClearRxCount : Clear RX count
22. ReadAllRxCount : Read All RX Count
23. ReadLegacyRxCount : Read Legacy RX Count
24. ReadMcsRxCount : Read MCS RX Count
25. StartCalibration : Start Calibration
26. ReadWifiAddress : Read Wifi address
27. WriteWifiAddress : Write Wifi address
28. ReadEthernetAddress : Read Ethernet address
29. WriteEthernetAddress : Write Ethernet address
30. GpioStart : GPIO Start
31. GpioRead : GPIO Read Pin Level
32. GpioWrite : GPIO Write Pin Level
33. GpioFinish : GPIO Finish
34. ReadGainTable : Read Gain Table
35. CommitGainTable : Commit Gain Table
36. SaveGainTableFile : Save Gain Table File
37. LoadGainTableFile : Load Gain Table File
38. UsbPinControl : USB Pin Control
*****
Use command help to get command detail parameter description
>PIC32MZ1025W1>

```

4. Enter startTx help to browse the CLI startTx help manual.

Figure 3-31. startTx help Manual

```

C:\Microchip\MCHPRT3_Setup_v1.0.2.7128\MCHPRT3_CLI.exe
9. ReadRemainingOTPSize : Read remaining OTP Size
10. ApplyFlashCal : Apply Flash Calibration
11. LoadCalParamsFile : Load Calibration Parameters File
12. CommitCalParams : Commit Calibration Parameters
13. StartTx : Start TX
14. StopTx : Stop TX
15. SetCcaThresholds : Set CCA thresholds
16. StartTone : Start Tone
17. StopTone : Stop Tone
18. StartRx : Start RX
19. StopRx : Stop RX
20. ReadRssi : Read RSSI
21. ClearRxCount : Clear RX count
22. ReadAllRxCount : Read All RX Count
23. ReadLegacyRxCount : Read Legacy RX Count
24. ReadMcsRxCount : Read MCS RX Count
25. StartCalibration : Start Calibration
26. ReadWifiAddress : Read Wifi address
27. WriteWifiAddress : Write Wifi address
28. ReadEthernetAddress : Read Ethernet address
29. WriteEthernetAddress : Write Ethernet address
30. GpioStart : GPIO Start
31. GpioRead : GPIO Read Pin Level
32. GpioWrite : GPIO Write Pin Level
33. GpioFinish : GPIO Finish
34. ReadGainTable : Read Gain Table
35. CommitGainTable : Commit Gain Table
36. SaveGainTableFile : Save Gain Table File
37. LoadGainTableFile : Load Gain Table File
38. UsbPinControl : USB Pin Control
*****
Use command help to get command detail parameter description

>PIC32MZ1025W1>startTx help
*****
Name      : StartTx
Brief     : Start TX
Format    : StartTx Arguments
Arguments :
    Channel=Ch, Ch is one of below
                2412, 2417, 2422, 2427, 2432, 2437, 2442
                2447, 2452, 2457, 2462, 2467, 2472
    RateType=R, R is one of Legacy, MCS
    DataRate=d, d is depend on RateType
                R equal to Legacy, d is one of
                1, 2, 5, 11, 6, 9, 12, 18, 24, 36, 48, 54
                R equal to MCS, d is one of
                MCS0, MCS1, MCS2, MCS3, MCS4, MCS5, MCS6, MCS7
    Duration=time, time is duration time, range is 1 ~ 9999
    PowerMode=mode, mode is Index or Value or TPCAuto or TPCOnce
    GainIndex=index, index for PowerMode configure to Index use, range is 0 ~ 255
    PowerValue=Value, value for PowerMode configure to Value use, range is 10 ~ 25, step is 0.25
    ChannelOffset=offset, offset for channel, it will use default if ChannelOffset ignore
                ChannelOffset can use only on power value mode
                ChannelOffset must integer number
    GI=sl, sl is Short or Long
    FrameLen=len, range is 1 ~ 1500
    EnableCCA=cca, cca is one of Enable, Disable
Success  : StartTx Success NvmType=t PageIndex=n
                NvmType=t, t is type of "Flash" or "OTP", only show on TPCAuto or TPCOnce
                PageIndex=n, n is one of 1 ~ 6, only show on TPCAuto or TPCOnce
Fail     : StartTx Error=n
                Error=n, n is count of error message will show
Note    :
                NvmType and PageIndex value is come from CommitGainTable command parameters
                if not yet execute CommitGainTable command
                NvmType default is "Flash". PageIndex default is 1
*****
>PIC32MZ1025W1>

```

3.7 PIC32MZ1025W1 Python 3 Information

This section describes the python3 example information of the PIC32MZ1025W1. For more details, refer to the `Python3_Example.chm`.

The user can refer to the example code in the PIC32MZ1025W1 package example folder, which provides details on how to use the `PIC32MZ1025W1.dll` file with the Python language to control the PIC32MZ1025W1. For more details, refer to [3.7.2. How to Run Python 3.6 Environment](#).

3.7.1 Python 3.6 Environment

Python 3.6 (v3.6.2:5fd33b5, Jul 8 2017, 04:14:34) [MSC v.1900 32 bit (Intel)] on win32

3.7.2 How to Run Python 3.6 Environment

The following are the steps to run the Python 3.6 environment:

1. Open **IDLE (Python 3.6 32-bit)** in the Python 3.6 folder from the Start menu.

Figure 3-32. Python 3.6 Package

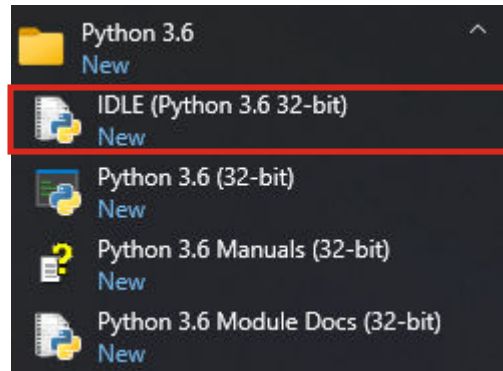

2. The following figure illustrates the IDLE window of Python 3.6.

Figure 3-33. Opening Window of IDLE

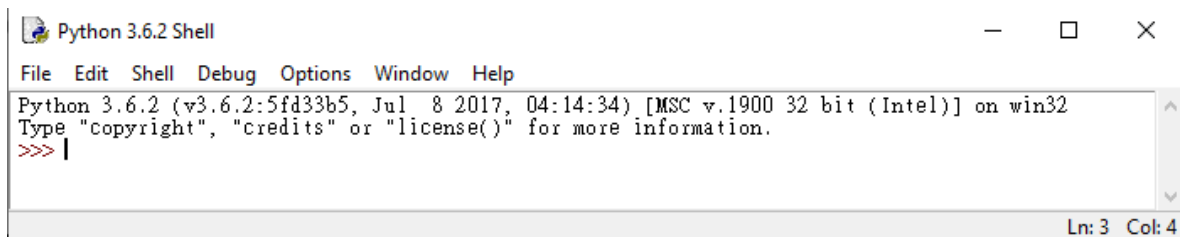

3. Go to *File>Open* and choose the PIC32MZ1025W1_GUI.py file (see the following figure).

Figure 3-34. Opening PIC32MZ1025W1_GUI .py File

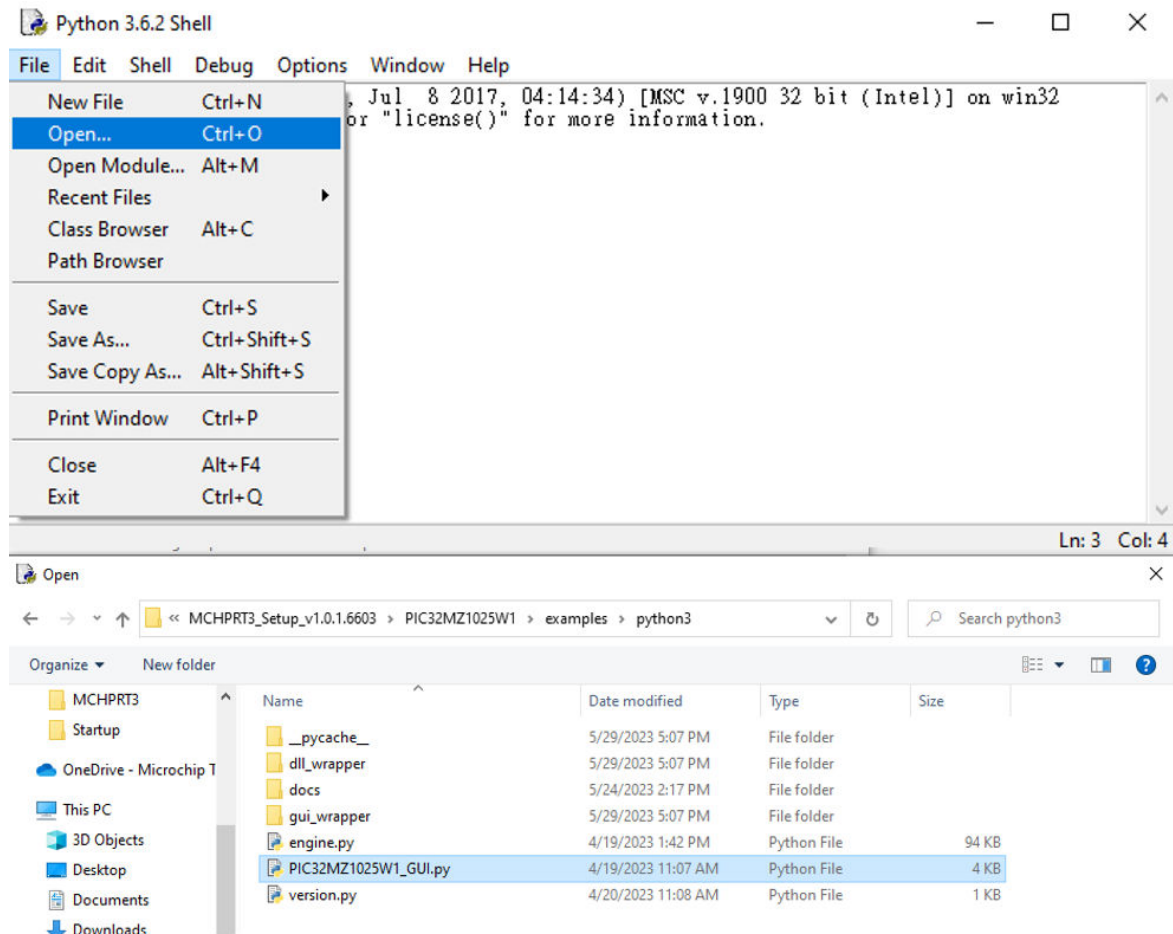

4. Go to *Run>Run Module* to execute the PIC32MZ1025W1_GUI .py file.

Figure 3-35. Run Module

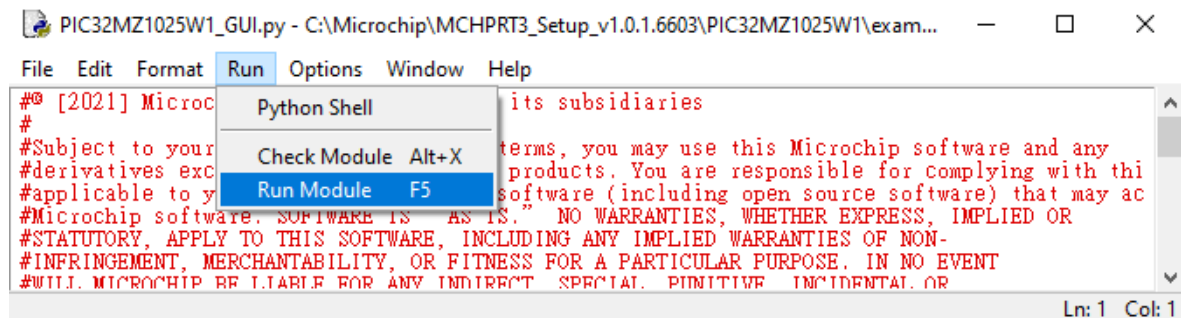

5. The Python 3.6 shell window displays the following message:

Figure 3-36. Python Shell Window Message

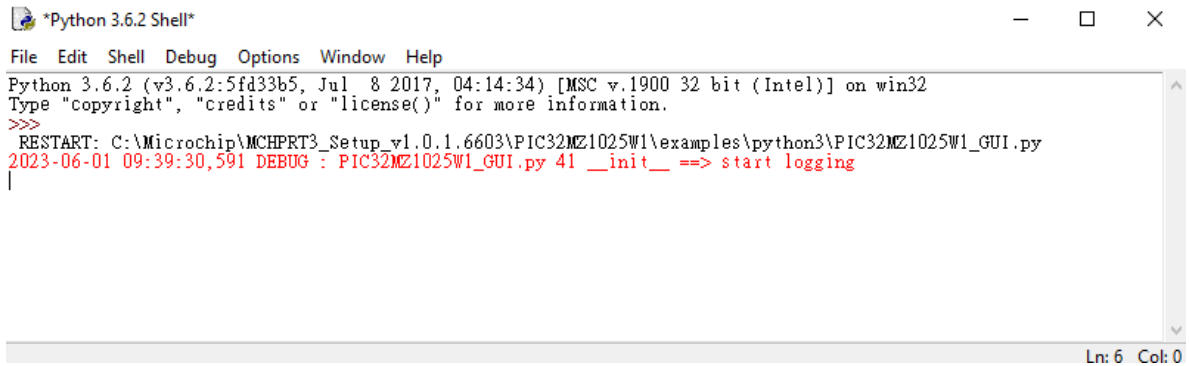

```

Python 3.6.2 Shell
File Edit Shell Debug Options Window Help
Python 3.6.2 (v3.6.2:5fd33b5, Jul 8 2017, 04:14:34) [MSC v.1900 32 bit (Intel)] on win32
Type "copyright", "credits" or "license()" for more information.
>>>
RESTART: C:\Microchip\MCHPRT3_Setup_v1.0.1.6603\PIC32MZ1025W1\examples\python3\PIC32MZ1025W1_GUI.py
2023-06-01 09:39:30,591 DEBUG : PIC32MZ1025W1_GUI.py 41 __init__ ==> start logging
|
Ln: 6 Col: 0

```

Note: If the shell window displays an error message, check if the source code is from the original MCHPRT3_Setup.exe installation folder.

6. Select the PIC32MZ1025W1.dll file to load the library and run example code.

Figure 3-37. Opening PIC32MZ1025W1.dll

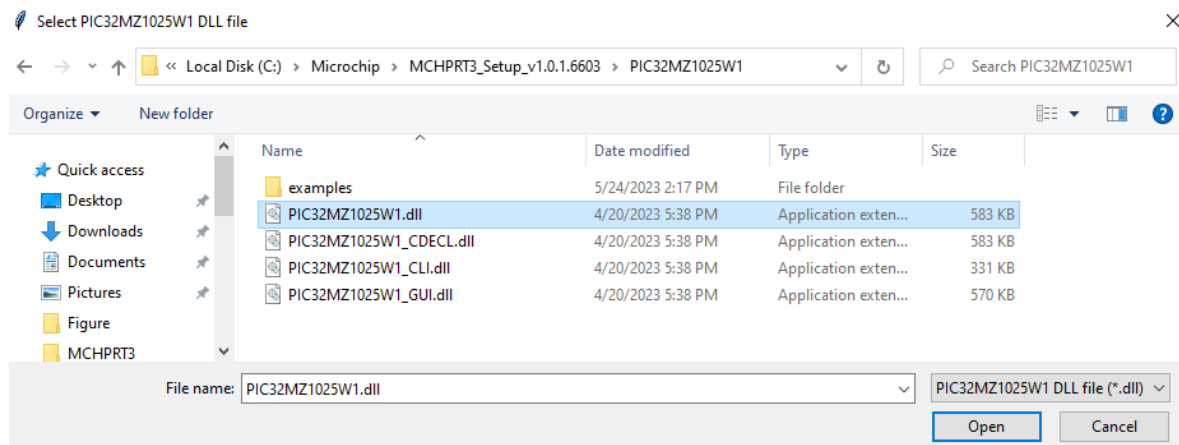

7. The following figure illustrates the Python shell window. After successfully loading the PIC32MZ1025W1.dll file, the Python shell window displays the .dll file version. In the Python shell window, the user can refer to the GUI running process to design a tool for themselves.

Figure 3-38. .dll File Version of PIC32MZ1025W1

```

2023-06-01 09:39:30,591 DEBUG : PIC32MZ1025W1_GUI.py 41 __init__ ==> start logging
2023-06-01 09:41:19,064 DEBUG : wrapper.py 109 load_dll ==>
2023-06-01 09:41:19,086 DEBUG : wrapper.py 124 load_dll ==> success
2023-06-01 09:41:19,089 DEBUG : wrapper.py 198 get_dll_version ==>
2023-06-01 09:41:19,091 DEBUG : wrapper.py 239 get_dll_version ==> DLL Version1 : 1
2023-06-01 09:41:19,094 DEBUG : wrapper.py 240 get_dll_version ==> DLL Version2 : 0
2023-06-01 09:41:19,097 DEBUG : wrapper.py 241 get_dll_version ==> DLL Version3 : 6599
2023-06-01 09:41:19,099 DEBUG : wrapper.py 242 get_dll_version ==> DLL FW Version : 2.6.0

```

8. The following figure illustrates the PIC32MZ1025W1 GUI Python example.
Note: Check if the version matches the device HUT code firmware version.
9. Select the device "COM Port", COMX, then click **Connect** to connect the PIC32MZ1025W1 device.
Note: COMX - "X" stands for the port number of the PC, which is the device it is connected to.

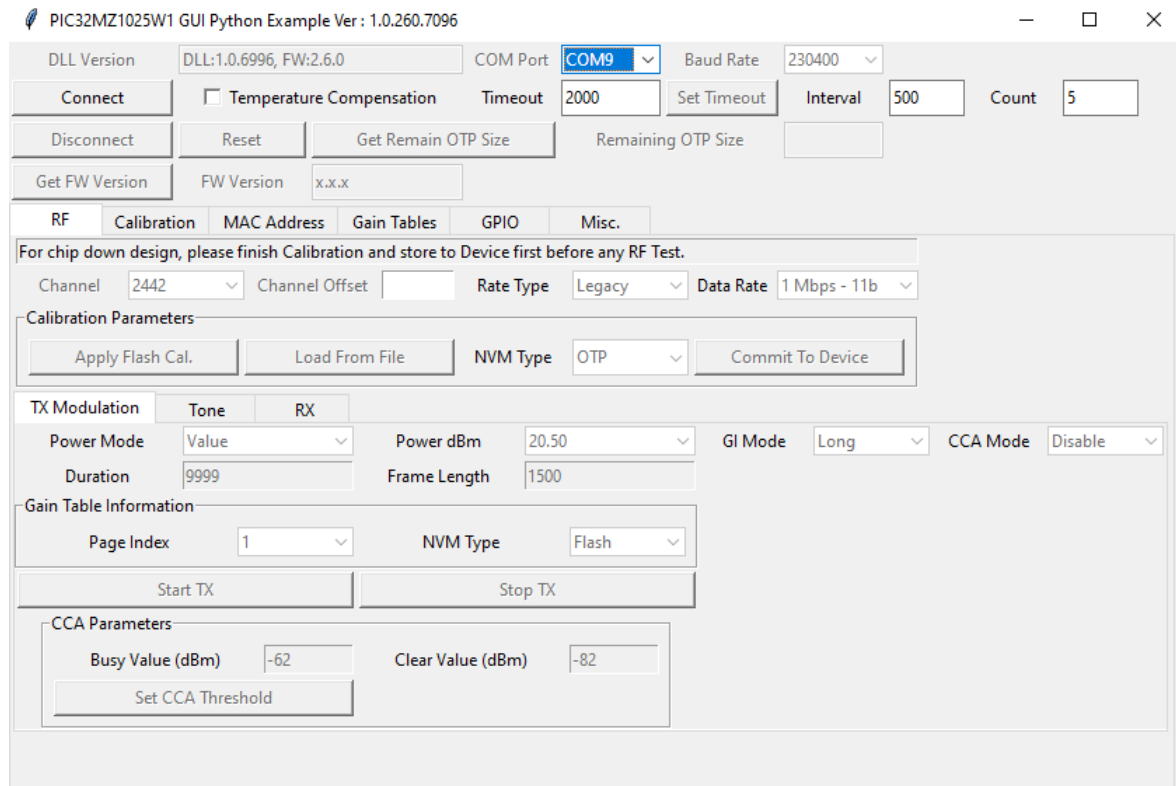
Figure 3-39. PIC32MZ1025W1 GUI Python Example

10. The following warning pop-up window appears after connecting the PIC32MZ1025W1 device. Click **Yes** to Reset the PIC32MZ1025W1 device.

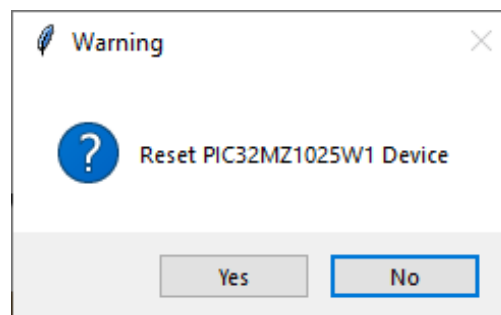
Figure 3-40. Reset PIC32MZ1025W1 Device Warning Message

11. After a successful connection, the following PIC32MZ1025W1 GUI Python example window appears.

Figure 3-41. Successful Connection of PIC32MZ1025W1 GUI Python Example Window

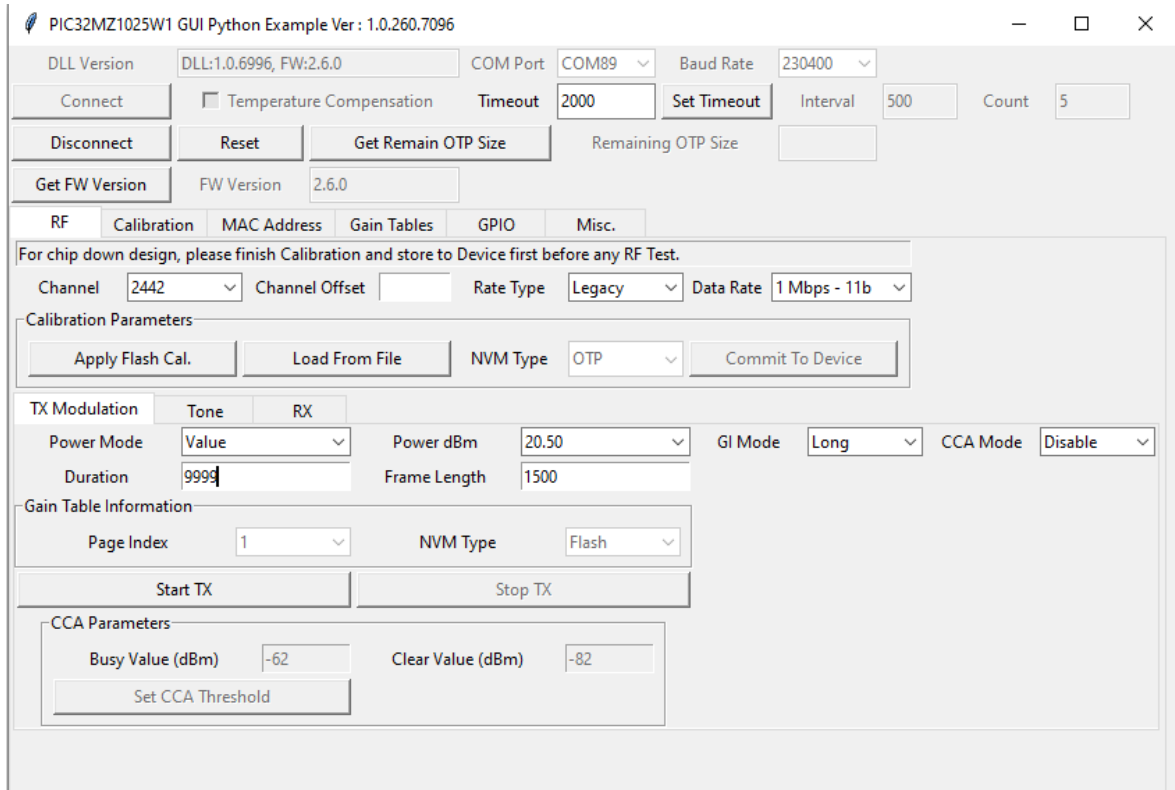

4. Document Revision History

The document revision history describes the changes that were implemented in the document. The changes are listed by revision, starting with the most current publication.

Revision	Date	Section	Description
B	10/2023	Document	<ul style="list-style-type: none"> Updated document content for PIC32MZ1025W1 PIC32MZ1025W1 GUI update for MCHPRT3 Tool Editorial Updates
		3.1. MPLAB X IPE HUT Code Programming Process with In-Circuit Serial Programming Header	<ul style="list-style-type: none"> Updated Figure 3-1 Removed MPLAB ICD 4 occurrence
		3.2. Getting Started with MCHPRT3 Tool GUI for PIC32MZ1025W1	<ul style="list-style-type: none"> Updated Figure 3-4
		3.4.4. Calibration Flow Demonstration	<ul style="list-style-type: none"> Added Note
		3.4.6. Gain Tables Demonstration	<ul style="list-style-type: none"> Updated Figure 3-23
		3.6.1. PIC32MZ1025W1 CLI Example	<ul style="list-style-type: none"> Updated all the images
		3.7.2. How to Run Python 3.6 Environment	<ul style="list-style-type: none"> Updated Figure 3-39 Updated Figure 3-41
A	09/2021	Document	Initial Revision

Microchip Information

The Microchip Website

Microchip provides online support via our website at www.microchip.com/. This website is used to make files and information easily available to customers. Some of the content available includes:

- **Product Support** – Data sheets and errata, application notes and sample programs, design resources, user’s guides and hardware support documents, latest software releases and archived software
- **General Technical Support** – Frequently Asked Questions (FAQs), technical support requests, online discussion groups, Microchip design partner program member listing
- **Business of Microchip** – Product selector and ordering guides, latest Microchip press releases, listing of seminars and events, listings of Microchip sales offices, distributors and factory representatives

Product Change Notification Service

Microchip’s product change notification service helps keep customers current on Microchip products. Subscribers will receive email notification whenever there are changes, updates, revisions or errata related to a specified product family or development tool of interest.

To register, go to www.microchip.com/pcn and follow the registration instructions.

Customer Support

Users of Microchip products can receive assistance through several channels:

- Distributor or Representative
- Local Sales Office
- Embedded Solutions Engineer (ESE)
- Technical Support

Customers should contact their distributor, representative or ESE for support. Local sales offices are also available to help customers. A listing of sales offices and locations is included in this document.

Technical support is available through the website at: www.microchip.com/support

Microchip Devices Code Protection Feature

Note the following details of the code protection feature on Microchip products:

- Microchip products meet the specifications contained in their particular Microchip Data Sheet.
- Microchip believes that its family of products is secure when used in the intended manner, within operating specifications, and under normal conditions.
- Microchip values and aggressively protects its intellectual property rights. Attempts to breach the code protection features of Microchip product is strictly prohibited and may violate the Digital Millennium Copyright Act.
- Neither Microchip nor any other semiconductor manufacturer can guarantee the security of its code. Code protection does not mean that we are guaranteeing the product is “unbreakable”. Code protection is constantly evolving. Microchip is committed to continuously improving the code protection features of our products.

Legal Notice

This publication and the information herein may be used only with Microchip products, including to design, test, and integrate Microchip products with your application. Use of this information in any other manner violates these terms. Information regarding device applications is provided only for your convenience and may be superseded by updates. It is your responsibility to ensure

that your application meets with your specifications. Contact your local Microchip sales office for additional support or, obtain additional support at www.microchip.com/en-us/support/design-help/client-support-services.

THIS INFORMATION IS PROVIDED BY MICROCHIP "AS IS". MICROCHIP MAKES NO REPRESENTATIONS OR WARRANTIES OF ANY KIND WHETHER EXPRESS OR IMPLIED, WRITTEN OR ORAL, STATUTORY OR OTHERWISE, RELATED TO THE INFORMATION INCLUDING BUT NOT LIMITED TO ANY IMPLIED WARRANTIES OF NON-INFRINGEMENT, MERCHANTABILITY, AND FITNESS FOR A PARTICULAR PURPOSE, OR WARRANTIES RELATED TO ITS CONDITION, QUALITY, OR PERFORMANCE.

IN NO EVENT WILL MICROCHIP BE LIABLE FOR ANY INDIRECT, SPECIAL, PUNITIVE, INCIDENTAL, OR CONSEQUENTIAL LOSS, DAMAGE, COST, OR EXPENSE OF ANY KIND WHATSOEVER RELATED TO THE INFORMATION OR ITS USE, HOWEVER CAUSED, EVEN IF MICROCHIP HAS BEEN ADVISED OF THE POSSIBILITY OR THE DAMAGES ARE FORESEEABLE. TO THE FULLEST EXTENT ALLOWED BY LAW, MICROCHIP'S TOTAL LIABILITY ON ALL CLAIMS IN ANY WAY RELATED TO THE INFORMATION OR ITS USE WILL NOT EXCEED THE AMOUNT OF FEES, IF ANY, THAT YOU HAVE PAID DIRECTLY TO MICROCHIP FOR THE INFORMATION.

Use of Microchip devices in life support and/or safety applications is entirely at the buyer's risk, and the buyer agrees to defend, indemnify and hold harmless Microchip from any and all damages, claims, suits, or expenses resulting from such use. No licenses are conveyed, implicitly or otherwise, under any Microchip intellectual property rights unless otherwise stated.

Trademarks

The Microchip name and logo, the Microchip logo, Adaptec, AVR, AVR logo, AVR Freaks, BesTime, BitCloud, CryptoMemory, CryptoRF, dsPIC, flexPWR, HELDO, IGLOO, JukeBlox, KeeLoq, Kleer, LANCheck, LinkMD, maXStylus, maXTouch, MediaLB, megaAVR, Microsemi, Microsemi logo, MOST, MOST logo, MPLAB, OptoLyzer, PIC, picoPower, PICSTART, PIC32 logo, PolarFire, Prochip Designer, QTouch, SAM-BA, SenGenuity, SpyNIC, SST, SST Logo, SuperFlash, Symmetricom, SyncServer, Tachyon, TimeSource, tinyAVR, UNI/O, Vectron, and XMEGA are registered trademarks of Microchip Technology Incorporated in the U.S.A. and other countries.

AgileSwitch, ClockWorks, The Embedded Control Solutions Company, EtherSynch, Flashtec, Hyper Speed Control, HyperLight Load, Libero, motorBench, mTouch, Powermite 3, Precision Edge, ProASIC, ProASIC Plus, ProASIC Plus logo, Quiet-Wire, SmartFusion, SyncWorld, TimeCesium, TimeHub, TimePictra, TimeProvider, and ZL are registered trademarks of Microchip Technology Incorporated in the U.S.A.

Adjacent Key Suppression, AKS, Analog-for-the-Digital Age, Any Capacitor, AnyIn, AnyOut, Augmented Switching, BlueSky, BodyCom, Clockstudio, CodeGuard, CryptoAuthentication, CryptoAutomotive, CryptoCompanion, CryptoController, dsPICDEM, dsPICDEM.net, Dynamic Average Matching, DAM, ECAN, Espresso T1S, EtherGREEN, EyeOpen, GridTime, IdealBridge, IGaT, In-Circuit Serial Programming, ICSP, INICnet, Intelligent Paralleling, IntelliMOS, Inter-Chip Connectivity, JitterBlocker, Knob-on-Display, MarginLink, maxCrypto, maxView, memBrain, Mindi, MiWi, MPASM, MPF, MPLAB Certified logo, MPLIB, MPLINK, mSiC, MultiTRAK, NetDetach, Omniscient Code Generation, PICDEM, PICDEM.net, PICKit, PICtail, Power MOS IV, Power MOS 7, PowerSmart, PureSilicon, QMatrix, REAL ICE, Ripple Blocker, RTAX, RTG4, SAM-ICE, Serial Quad I/O, simpleMAP, SimpliPHY, SmartBuffer, SmartHLS, SMART-I.S., storClad, SQI, SuperSwitcher, SuperSwitcher II, Switchtec, SynchroPHY, Total Endurance, Trusted Time, TSHARC, Turing, USBCheck, VariSense, VectorBlox, VeriPHY, ViewSpan, WiperLock, XpressConnect, and ZENA are trademarks of Microchip Technology Incorporated in the U.S.A. and other countries.

SQTP is a service mark of Microchip Technology Incorporated in the U.S.A.

The Adaptec logo, Frequency on Demand, Silicon Storage Technology, and Symmcom are registered trademarks of Microchip Technology Inc. in other countries.

GestIC is a registered trademark of Microchip Technology Germany II GmbH & Co. KG, a subsidiary of Microchip Technology Inc., in other countries.

All other trademarks mentioned herein are property of their respective companies.

© 2021-2023, Microchip Technology Incorporated and its subsidiaries. All Rights Reserved.

ISBN: 978-1-6683-3198-9

Quality Management System

For information regarding Microchip's Quality Management Systems, please visit www.microchip.com/quality.

Worldwide Sales and Service

AMERICAS	ASIA/PACIFIC	ASIA/PACIFIC	EUROPE
<p>Corporate Office 2355 West Chandler Blvd. Chandler, AZ 85224-6199 Tel: 480-792-7200 Fax: 480-792-7277 Technical Support: www.microchip.com/support Web Address: www.microchip.com</p> <p>Atlanta Duluth, GA Tel: 678-957-9614 Fax: 678-957-1455</p> <p>Austin, TX Tel: 512-257-3370</p> <p>Boston Westborough, MA Tel: 774-760-0087 Fax: 774-760-0088</p> <p>Chicago Itasca, IL Tel: 630-285-0071 Fax: 630-285-0075</p> <p>Dallas Addison, TX Tel: 972-818-7423 Fax: 972-818-2924</p> <p>Detroit Novi, MI Tel: 248-848-4000</p> <p>Houston, TX Tel: 281-894-5983</p> <p>Indianapolis Noblesville, IN Tel: 317-773-8323 Fax: 317-773-5453 Tel: 317-536-2380</p> <p>Los Angeles Mission Viejo, CA Tel: 949-462-9523 Fax: 949-462-9608 Tel: 951-273-7800</p> <p>Raleigh, NC Tel: 919-844-7510</p> <p>New York, NY Tel: 631-435-6000</p> <p>San Jose, CA Tel: 408-735-9110 Tel: 408-436-4270</p> <p>Canada - Toronto Tel: 905-695-1980 Fax: 905-695-2078</p>	<p>Australia - Sydney Tel: 61-2-9868-6733</p> <p>China - Beijing Tel: 86-10-8569-7000</p> <p>China - Chengdu Tel: 86-28-8665-5511</p> <p>China - Chongqing Tel: 86-23-8980-9588</p> <p>China - Dongguan Tel: 86-769-8702-9880</p> <p>China - Guangzhou Tel: 86-20-8755-8029</p> <p>China - Hangzhou Tel: 86-571-8792-8115</p> <p>China - Hong Kong SAR Tel: 852-2943-5100</p> <p>China - Nanjing Tel: 86-25-8473-2460</p> <p>China - Qingdao Tel: 86-532-8502-7355</p> <p>China - Shanghai Tel: 86-21-3326-8000</p> <p>China - Shenyang Tel: 86-24-2334-2829</p> <p>China - Shenzhen Tel: 86-755-8864-2200</p> <p>China - Suzhou Tel: 86-186-6233-1526</p> <p>China - Wuhan Tel: 86-27-5980-5300</p> <p>China - Xian Tel: 86-29-8833-7252</p> <p>China - Xiamen Tel: 86-592-2388138</p> <p>China - Zhuhai Tel: 86-756-3210040</p>	<p>India - Bangalore Tel: 91-80-3090-4444</p> <p>India - New Delhi Tel: 91-11-4160-8631</p> <p>India - Pune Tel: 91-20-4121-0141</p> <p>Japan - Osaka Tel: 81-6-6152-7160</p> <p>Japan - Tokyo Tel: 81-3-6880-3770</p> <p>Korea - Daegu Tel: 82-53-744-4301</p> <p>Korea - Seoul Tel: 82-2-554-7200</p> <p>Malaysia - Kuala Lumpur Tel: 60-3-7651-7906</p> <p>Malaysia - Penang Tel: 60-4-227-8870</p> <p>Philippines - Manila Tel: 63-2-634-9065</p> <p>Singapore Tel: 65-6334-8870</p> <p>Taiwan - Hsin Chu Tel: 886-3-577-8366</p> <p>Taiwan - Kaohsiung Tel: 886-7-213-7830</p> <p>Taiwan - Taipei Tel: 886-2-2508-8600</p> <p>Thailand - Bangkok Tel: 66-2-694-1351</p> <p>Vietnam - Ho Chi Minh Tel: 84-28-5448-2100</p>	<p>Austria - Wels Tel: 43-7242-2244-39 Fax: 43-7242-2244-393</p> <p>Denmark - Copenhagen Tel: 45-4485-5910 Fax: 45-4485-2829</p> <p>Finland - Espoo Tel: 358-9-4520-820</p> <p>France - Paris Tel: 33-1-69-53-63-20 Fax: 33-1-69-30-90-79</p> <p>Germany - Garching Tel: 49-8931-9700</p> <p>Germany - Haan Tel: 49-2129-3766400</p> <p>Germany - Heilbronn Tel: 49-7131-72400</p> <p>Germany - Karlsruhe Tel: 49-721-625370</p> <p>Germany - Munich Tel: 49-89-627-144-0 Fax: 49-89-627-144-44</p> <p>Germany - Rosenheim Tel: 49-8031-354-560</p> <p>Israel - Ra'anana Tel: 972-9-744-7705</p> <p>Italy - Milan Tel: 39-0331-742611 Fax: 39-0331-466781</p> <p>Italy - Padova Tel: 39-049-7625286</p> <p>Netherlands - Drunen Tel: 31-416-690399 Fax: 31-416-690340</p> <p>Norway - Trondheim Tel: 47-72884388</p> <p>Poland - Warsaw Tel: 48-22-3325737</p> <p>Romania - Bucharest Tel: 40-21-407-87-50</p> <p>Spain - Madrid Tel: 34-91-708-08-90 Fax: 34-91-708-08-91</p> <p>Sweden - Gothenberg Tel: 46-31-704-60-40</p> <p>Sweden - Stockholm Tel: 46-8-5090-4654</p> <p>UK - Wokingham Tel: 44-118-921-5800 Fax: 44-118-921-5820</p>