



# MICROCHIP

## TSHARC-12S Touch Screen Microcontroller Application Guide

### Ver. 1.2

3.3V-5vDC 20-Pin

SOIC or SSOP

12 – Bit Resolution

TTL, RS-232, PS/2 and SPI

Supports 4, 5, and 8 wire analog resistive touch screens

Microchip Technology Inc. uses standard silicon to produce a variety of TSHARC touch screen controller chip solutions. The chip part number and chip revision is laser marked on the top surface of the each microcontroller.

#### ***Document Revision and Copyright***

Document Name: TSHARC-12S\_Chip\_Application\_Guide\_090714  
Document Date: July 14, 2009

#### ***Copyright Microchip Technology Inc.***

***1995 – 2009 All rights reserved***

Microchip TSHARC™ and UniWinDriver™ are the exclusive trademarks of Microchip Technology Inc.  
All Rights Reserved.

#### ***Contact Information***

**Microchip Technology Inc**  
9055 N. 51st Street Unit H  
Brown Deer, WI 53223  
[www.microchip.com/TSHARC](http://www.microchip.com/TSHARC)  
Main Phone: 414-355-4675  
Main Fax: 414-355-4775



## Important Documents and User Information

Use this document as a guide only. The information contained in this document is subject to change without notice. This document, and all of its contents, is protected under International and U.S. copyright law. Microchip Technology trademarks, patents and copyrights are the exclusive property of Microchip Technology Inc. and may not be used without the express written consent of Microchip Technology Inc.

Due to the vast range of application variables that fall outside of Microchip's expertise and control, Microchip assumes no responsibility for the usability or the suitability of Microchip products in customer application(s). Microchip assumes those responsible for the application and use of Microchip Technology products and documentation have taken all necessary steps to insure that the application of Microchip products meet any and all safety and performance requirements including any laws, regulations, codes and standards associated with the application. In no case does Microchip warrant the usability or suitability of its products in any medical, aviation, military or other life critical applications. User should contact Microchip Technology before integrating any Microchip hardware or software product into these types of applications.

All Microchip standard software products, including but not limited to device driver software, are provided "as is" and may be used exclusively with an authentic Microchip TSHARC touch screen controller. Microchip does not guarantee the usability of any of its software products.

Microchip Technology warrants to the original purchaser, or a third party who is listed on the Microchip "Multi Party Authorization Agreement", that for the warranty period identified by Microchip warranty for the specific product that you have purchased, that the goods will be in conformance with Microchip specifications. In addition to Microchip specifications, the warrantee includes Non-Microchip specifications agreed-to, in writing, by Microchip in advance for the limited purpose between the customer and Microchip Technology Inc. The warrantee also insures that the goods will be free from defects in design and material for the warrantee period. Microchip Technology, at its option, will repair or replace the nonconforming or defective goods, issue a credit memorandum, or refund the purchase price, as its sole obligation: provided that the nonconforming or defective goods are rejected in writing (including a reasonable failure analysis statement) to Microchip Technology and returned to Microchip Technology within the relevant warranty period and provided that the nonconformance or defect was not caused by misuse, alteration, accident, or abnormal conditions of storage, operation or handling, as determined by Microchip Technology.

THIS WARRANTY IS YOUR SOLE AND EXCLUSIVE REMEDY AND IS IN LIEU OF ALL OTHER WARRANTIES, EXPRESS OR IMPLIED, INCLUDING ANY IMPLIED WARRANTY OF MERCHANTABILITY OR FITNESS FOR A PARTICULAR PURPOSE, FURTHER, MICROCHIP TECHNOLOGY INC SHALL NOT BE LIABLE FOR ANY DIRECT, INDIRECT, SPECIAL, INCIDENTAL OR CONSEQUENTIAL DAMAGE OR LOSSES, INCLUDING LOSS OF PROFITS, BUSINESS INTERRUPTION, OR OTHER PECUNIARY LOSS, WHETHER ARISING FROM BREACH OF WARRANTY OR BASED ON CONTRACT, FUNDAMENTAL BREACH OR ANY OTHER THEORY. SINCE SOME JURISDICTIONS DO NOT ALLOW LIMITATIONS OF THE TERMS OF ANY IMPLIED WARRANTY, OR EXCLUSION OR LIMITATION OF INCIDENTAL OF CONSEQUENTIAL DAMAGES, THE LIMITATIONS AND EXCLUSIONS OF THIS WARRANTY MAY NOT APPLY TO YOU.

### General Information

#### *Mailing address*

**Microchip Technology Inc.**  
9055 North 51<sup>st</sup> Street, Suite H  
Brown Deer, WI 53223  
Phone: 414-355-4675  
Fax: 414-355-4775

#### *World Wide Web*

[www.microchip.com/TSHARC](http://www.microchip.com/TSHARC)

#### *Support E-Mail Address*

[support@hampshirecompany.com](mailto:support@hampshirecompany.com)

### Copyright Information

This manual is ©1995-2009 Microchip Technology Inc. Reproduction of the contents of this copyrighted material in whole or in part, by any means, mechanically or electronic, for any purpose, without the written permission of Microchip Technology Inc is prohibited. Microchip Technology Inc., Microchip® TSHARC™, the TSHARC logo, and UniWinDriver™ are Trademarks of Microchip Technology Inc. All Rights Reserved.

### Edition Information

Printed on: July 14, 2009  
Document Part number: TSHARC-12S\_Chip\_Application\_Guide\_090714

## Table of Contents

IMPORTANT DOCUMENTS AND USER INFORMATION .....	2
MAILING ADDRESS .....	2
WORLD WIDE WEB.....	2
SUPPORT E-MAIL ADDRESS .....	2
TABLE OF CONTENTS.....	3
TABLE OF FIGURES .....	3
INTRODUCTION .....	4
PRODUCT DESCRIPTION .....	4
TSHARC-12S CORE FEATURES.....	4
ELECTRICAL CHARACTERISTICS (ABSOLUTE MAXIMUM RATINGS) .....	4
PART NUMBERS .....	5
TOUCH SCREEN OVERVIEW .....	5
SOFTWARE DEVICE DRIVERS.....	5
COMMUNICATION FORMATS.....	6
SPI CONSIDERATIONS AND FORMAT.....	6
DATA FORMAT .....	6
TIMING REQUIREMENTS .....	6
GENERAL ESD CONSIDERATIONS.....	7
IMPLEMENTATION .....	7
TOUCH SCREEN PIN-OUT CONFIGURATIONS .....	8
HAMPSHIRE ORIGIN.....	8
4-WIRE .....	8
5-WIRE .....	8
8-WIRE.....	9
TSHARC-12S 20 PIN SOIC MECHANICAL SPECIFICATION .....	10
TSHARC-12S 20 PIN SSOP MECHANICAL SPECIFICATION.....	11
TSHARC-12S SCHEMATIC / BILL OF MATERIAL REFERENCE MATRIX .....	12
APPLICATION NOTES .....	12
SCHEMATIC S-101015.....	13
BILL OF MATERIALS B-101015 .....	14
SCHEMATIC S-103015.....	15
BILL OF MATERIALS B-103015 .....	16
NOTES .....	17

## Table of Figures

TABLE 1: TSHARC RS232 4-BYTE PROTOCOL .....	6
TABLE 3: TSHARC PS/2 PROTOCOL .....	6
TABLE 4: SPI INTERFACE DESCRIPTIONS.....	6
TABLE 5: SPI DATA FORMAT.....	6
FIGURE 1: SPI PACKET TIMING DIAGRAM.....	6
TABLE 6: SPI TIMING CHARACTERISTICS.....	7
TABLE 7: JUMPER CONFIGURATION FOR S-101015.....	12
TABLE 8: JUMPER CONFIGURATION FOR S-103015.....	12

## Introduction

This manual has been written for users of the Microchip **TSHARC-12S** touch screen micro-controller. The TSHARC touch screen controller chips and software described within this document are assumed to be used with four, five or eight wire analog resistive touch screen products manufactured by a variety of touch screen manufacturers. Touch screens between manufacturers vary with regards to light transmission, sensitivity, contact resistance, capacitance and other electrical characteristics. Because touch screen quality and electrical characteristics may vary between touch screen technologies and manufacturers the actual, overall performance may vary between touch screen overlay manufacturers' products.

A great deal of attention has been paid to eliminate potential problems with various touch screen manufacturers. We have identified substantial specification variance within each manufacturer and between manufacturers touch screens. While most of the manufactures we tested did fall within a functional specification, it is important to request electrical and mechanical specifications from your touch screen overlay manufacturer to insure uniform quality and performance. The specification details that should be provided by your touch screen overlay supplier include lead to lead resistance, sheet resistance, and linearity of ITO.

## Product Description

The TSHARC-12S controller board chip supports PS/2 and RS232 communications and for any manufacturers' 4, 5 or 8 wire analog resistive touch sensors. Non-standard stock options are also available, including TTL communication and SPI. For further information about these options, please contact Microchip Technology.

## TSHARC-12S Core Features

- **RoHS Compliant**
- **Standard and Industrial-Rated Available**
  - **Standard 0C to +70C**
  - **Industrial -40C to +85C**
- Power-up Timer (PWRT)
- Brown Out Detect
- Brown out Voltage: 2.7v
- Oscillator Start-up Timer (OST)
- Watchdog Timer (WDT)
- SSOP and SOIC Packages Available
- True 12-bit ratio metric analog to digital converter
- Supported Communication Types
  - 4 byte RS232 and PS/2
  - SPI and TTL available. Please contact Microchip for this option
- Supports all manufacturers analog resistive touch screens.
  - 4 wire
  - 5 wire
  - 8 wire
- Touch Screen Resistance Specification is 50 – 2k ohm sheet resistance lead to lead.

## Electrical Characteristics (Absolute Maximum Ratings)

Ambient temperature under bias (Operating) .....	-65°C to +150°C
Storage temperature .....	-55°C to +125°C
Voltage on any pin with respect to Vss .....	-0.3V to (VDD + 0.3V)
Voltage on VDD with respect to Vss .....	-0.3V to +7.5V
Total power dissipation (Note 1) .....	1.0W
Maximum current out of Vss pin .....	300 mA
Maximum current into VDD pin .....	250 mA
Input clamp current, I <sub>IK</sub> (V <sub>I</sub> < 0 or V <sub>I</sub> > VDD).....	±20 mA
Output clamp current, I <sub>OK</sub> (V <sub>O</sub> < 0 or V <sub>O</sub> > VDD) .....	±20 mA
Maximum output current sunk by any I/O pin.....	25 mA
Maximum output current sourced by any I/O pin .....	25 mA
Maximum current sunk by all ports .....	200 mA
Maximum current sourced by all ports .....	200 mA

Note 1: Power dissipation is calculated as follows:  $P_{dis} = V_{DD} \times \{I_{DD} - \text{© } I_{OH}\} + \text{© } \{(V_{DD} - V_{OH}) \times I_{OH}\} + \text{© } (V_{OL} \times I_{OL})$   
2: Voltage spikes below Vss at the MCLR/VPP/RE3 pin, inducing currents greater than 80 mA, may cause latch-up. Thus, a series resistor of approximately 75 Ohms should be used when applying a "low" level to the MCLR/VPP/ RE3 pin, rather than pulling this pin directly to Vss.

## Part Numbers

HS12-100P0S/12PS30	Std. SSOP Pkg
HS12-100P0S/12PS30TR	Std. SSOP Pkg. Tape and Reel
HS12-100PAS/12PS30	3.3V Ind. SSOP Pkg
HS12-100PAS/12PS30TR	3.3V Ind. SSOP Pkg Tape and Reel
HS12-100PIS/12PS30	5V Ind. SSOP Pkg.
HS12-100PIS/12PS30TR	5V Ind. SSOP Pkg. Tape and Reel

HS12-100S0S/12SS30	Std. SOIC Pkg
HS12-100S0S/12SS30TR	Std. SOIC Pkg. Tape and Reel
HS12-100SAS/12SS30	3.3V Ind. SOIC Pkg
HS12-100SAS/12SS30TR	3.3V Ind. SOIC Pkg Tape and Reel
HS12-100SIS/12SS30	5V Ind. SOIC Pkg.
HS12-100SIS/12SS30TR	5V Ind. SOIC Pkg. Tape and Reel

## Touch Screen Overview

4 and 8 wire touch screens are typically produced with higher resistance transparent conductive film (ITO Indium Tin Oxide) than 5 wire touch screens. Most often touch screen resistances falls within 100 – 400 Ohm per square. Because 4 and 8 wire touch screens typically have a higher resistance than 5 wire sensors, you will find most battery powered applications using this technology. You will also find that 4 and 8 wire touch screens are more linear than 5 wire. The advantage of a 5 wire touch screen is that they are typically more mechanically durable (top sheet does not need to be linear) and are less affected by environmental variation. Five Wire touch screens come in a wide variety of sheet resistance. In some cases, because of the 5 wire construction, the resistance may be lower than the 50 ohm specification. While these touch screens require more power to drive them, this does not imply poor quality.

Once resistance drops below an optimum level so does the resolution. In contrast, as resistance increases, depending upon the construction, contact resistance begins to negatively affect the touch screen's performance. The negative effect of a high or low resistance touch screen can be managed by properly implementing the correct circuit. It should be understood that extremes in either direction will negatively influence the performance of any efficient circuit design. In order to maximize efficiency and performance a higher resistance, linear, environmentally stable touch screen is recommended.

Your product design requirements will help you identify the touch screen technology and construction that will best suit your application. Please contact Microchip Technology Inc. for more unbiased touch screen material science information and a list of recommended TSHARC controller designs to fit your application.

## Software Device Drivers

Microchip Technology has device driver software available for all TSHARC touch screen controller chip and board solutions. The software drivers may be downloaded at no additional charge at: [www.microchip.com/TSHARC](http://www.microchip.com/TSHARC). Reported Microchip resolution is dependent upon the hardware A-D converter specification. TSHARC device driver software is designed to deliver true 10- or 12-bit hardware resolution respective to the touch screen controller hardware.

The TSHARC device driver software enables you to configure the touch screen operation to meet your needs. The following is a list of features available with Microchip's software:

- 1) Touch Screen Linearization, Alignment, and Calibration
- 2) Multi-monitor calibration and configuration
- 3) Adjustable calibration inset
- 4) Edge acceleration
- 5) Touch modes
  - a. Normal mouse emulation
  - b. Touch Up mode
  - c. Touch Down mode
- 6) User adjustable Configurations
  - a. Microchip's proprietary touch screen friendly timed right click event
  - b. Touch event area setting
  - c. Touch sound enable / disable
- 7) Other special features also included. Please see the complete driver manuals available at the [www.microchip.com/TSHARC](http://www.microchip.com/TSHARC) web site for further details.

*Note: TSHARC device drivers vary between operating systems and operating system varieties and versions. Currently Hampshire supports the following Windows® Operating systems: DOS, Win3.1x, 9x, ME, XP, XPe, 2k, CE, CENet, Tablet. TSHARC driver for Linux, and MAC are also included with all TSHARC touch screen controller products.*

## Communication Formats

Byte	Bit 7	Bit 6	Bit 5	Bit 4	Bit 3	Bit 2	Bit 1	Bit 0
1	1	P	X11	X10	X9	Y11	Y10	Y9
2	0	X8	X7	X6	X5	X4	X3	X2
3	0	Y8	Y7	Y6	Y5	Y4	Y3	Y2
4	0	0	0	0	X1	X0	Y1	Y0

**Table 1: TSHARC RS232 4-Byte Protocol**

Byte	Bit 7	Bit 6	Bit 5	Bit 4	Bit 3	Bit 2	Bit 1	Bit 0
1	1	P	X11	X10	X9	Y11	Y10	Y9
2	0	X8	X7	X6	X5	X4	X3	X2
3	0	Y8	Y7	Y6	Y5	Y4	Y3	Y2
4	0	0	0	0	X1	X0	Y1	Y0

**Table 2: TSHARC PS/2 Protocol**

Where:

P	- 0 Pen-Up, 1 Pen-Down
X11-X0	- 12 bit X position data
Y11-Y0	- 12 bit Y position data
PU	- 0 no Pen-Up, 1 Pen-Up
PD	- 0 no Pen-Down, 1 Pen-Down
CK7-CK0	- AAH + 55H + Sum of Bytes 2 through 9

## SPI Considerations and Format

The TSHARC-12S controller can be directly connected to a microcontroller or microprocessor via a simple 3 wire interface. This interface uses an Interrupt Request, Clock, and Data line.

Symbol	I/O	Description
TIRQ	Output	t request line. Pulled high when the TSHARC-XXsc has data to transmit
TCLK	Input	Clock line. Driven by the Host to clock the data out of the TSHARC-XXsc
TDATA	Output	Data line. Data is paced on the TDATA line on TCLK↓. Data is read by the host at TCLK↑

**Table 3: SPI Interface Descriptions**

### Data Format

Data is transmitted from the controller as 1 25-bit packet MSB first.

Bit 25	24	23	22	21	20	19	18	17	16	14	13	12
P	X11	X10	X9	X8	X7	X6	X5	X4	X3	X2	X1 <sup>t</sup>	X0 <sup>t</sup>
Bit 11	10	9	8	7	6	5	4	3	2	1	0	
Y11	Y10	Y9	Y8	Y7	Y6	Y5	Y4	Y3	Y2	Y1 <sup>t</sup>	Y0 <sup>t</sup>	

**Table 4: SPI Data Format**

Where:

X11 – X0:	12 bit X position data
Y11 – Y0:	12 bit Y position data
P :	1 for Pendown, 0 for Penup

The TSHARC-XXsc controllers operate in a stream mode. While the user is touching the screen data is continuously transmitted until the user lifts up the pen. At Penup only one packet is sent indicating Penup, no more data is transmitted until the screen is touched again.

### Timing Requirements

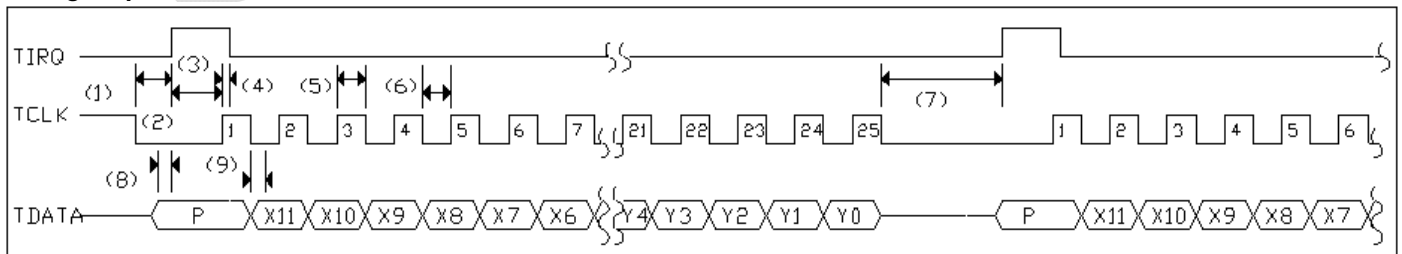

**Figure 1: SPI Packet Timing Diagram.**

Parameter No.	Sym	Description	Min	Typ	Max	Units
1 <sup>1</sup>	TCLK <sub>inh</sub>	Holding TCLK high to inhibit transmission	0	-	∞	μs
2 <sup>2</sup>	TCLK↓TIRQ↑	Time between TCLK low and TIRQ high		24		μs
3	TIRQ↑TCLK↑	Time from TIRQ high to first TCLK high	8	-	1E <sup>5</sup>	μs
4	TCLK↑TIRQ↓	Time between TCLK high and TIRQ low		3		μs
5 <sup>3,4</sup>	TCLK↑	TCLK high time	13	-	7000	μs
6 <sup>3</sup>	TCLK↓	TCLK low time	13	-	7000	μs
7 <sup>5,6</sup>	TIRQ-TIRQ	Time between continuous transmission without TCLK <sub>inh</sub>	10	-	46	ms
8	TDATA <sub>ava</sub>	Time from TDATA available to TIRQ high	7	-	-	μs
9	TDATA <sub>change</sub>	Time from TCLK low to TDATA change	7	-	-	μs

**Table 5: SPI Timing Characteristics**

<sup>1</sup> This parameter will not inhibit an active transmission

<sup>2</sup> This parameter is only used if the TCLK is used to inhibit transmission

<sup>3</sup> Times greater than 7000μs will cause a watchdog timer reset

<sup>4</sup> TDATA available at TCLK high

<sup>5</sup> Timing is dependent on total 25-clock cycle

<sup>6</sup> The TSHARC-XXsc uses a dynamic sampling routine whereby the sample rate is varied based upon the velocity of the pen movement

## General ESD Considerations

### Implementation

The TSHARC-12S controller design has internal static protection to guard against static discharge from the touch screen to the controller. This static protection is only effective once the board is grounded properly. Adequate static precautions must be taken when connecting the TSHARC controller to the application. In some applications, it may be necessary to further protect your controller board design from excess transient voltage. If it is believed that the application will require additional static protection, the appropriate static protection needed to protect the electronics from transient voltage is up to the customer. **Failure to take the necessary precautions may result in damage to your controller. Microchip Technology Inc. does not warrantee the controller for static voltage damage.**

**For additional information about Microchip's ESD testing procedures, please contact Microchip Technology Inc.**

Email: [support@hampshirecompany.com](mailto:support@hampshirecompany.com)

Telephone: (414) 355-4675

## Touch Screen Pin-Out Configurations

### Hampshire Origin

To remain consistent with Microsoft Window's operating systems, Hampshire Company has chosen our relative origin to remain in the upper left corner.

In emulation mode, the origin will be in the lower left corner. This is done automatically in the firmware to remain consistent with our standard origin by adding an additional flip-state. This flip-state allows both our standard origin and the emulated origin to be recognized by the controller, depending on what operation mode is chosen.

Hampshire firmware will output any of the 8 possible flip-states when the EEPROM is properly configured.

### 4-Wire

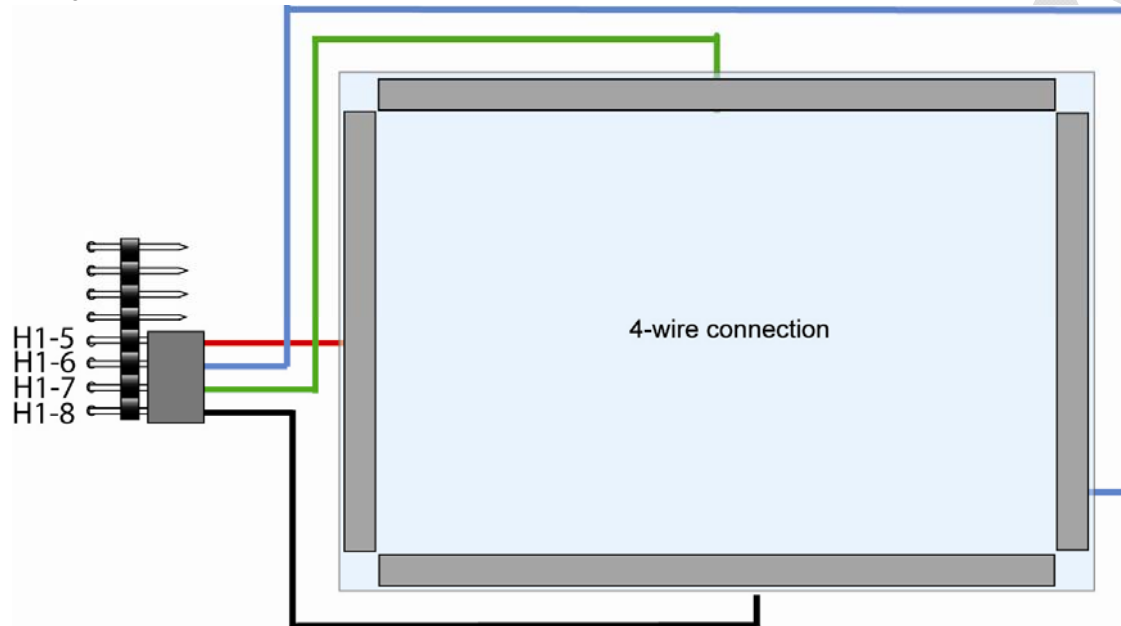

### 5-Wire

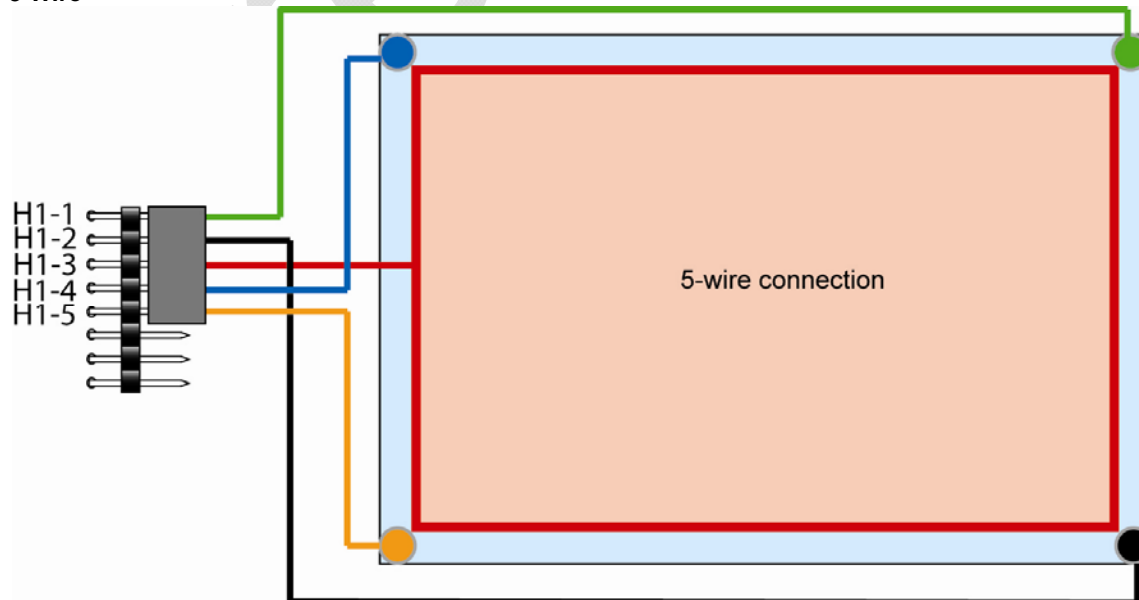

8-Wire

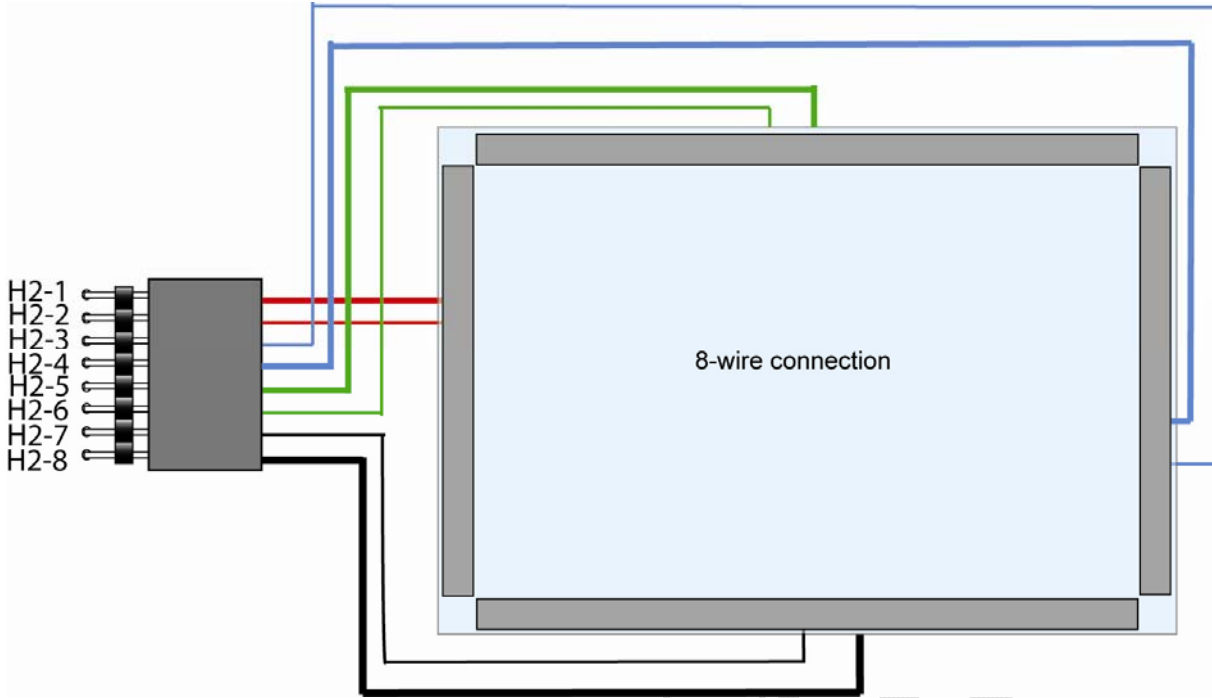

preliminary

TSHARC-12S 20 Pin SOIC Mechanical Specification

20-Lead Plastic Small Outline (SO) – Wide, 300 mi (SOIC)

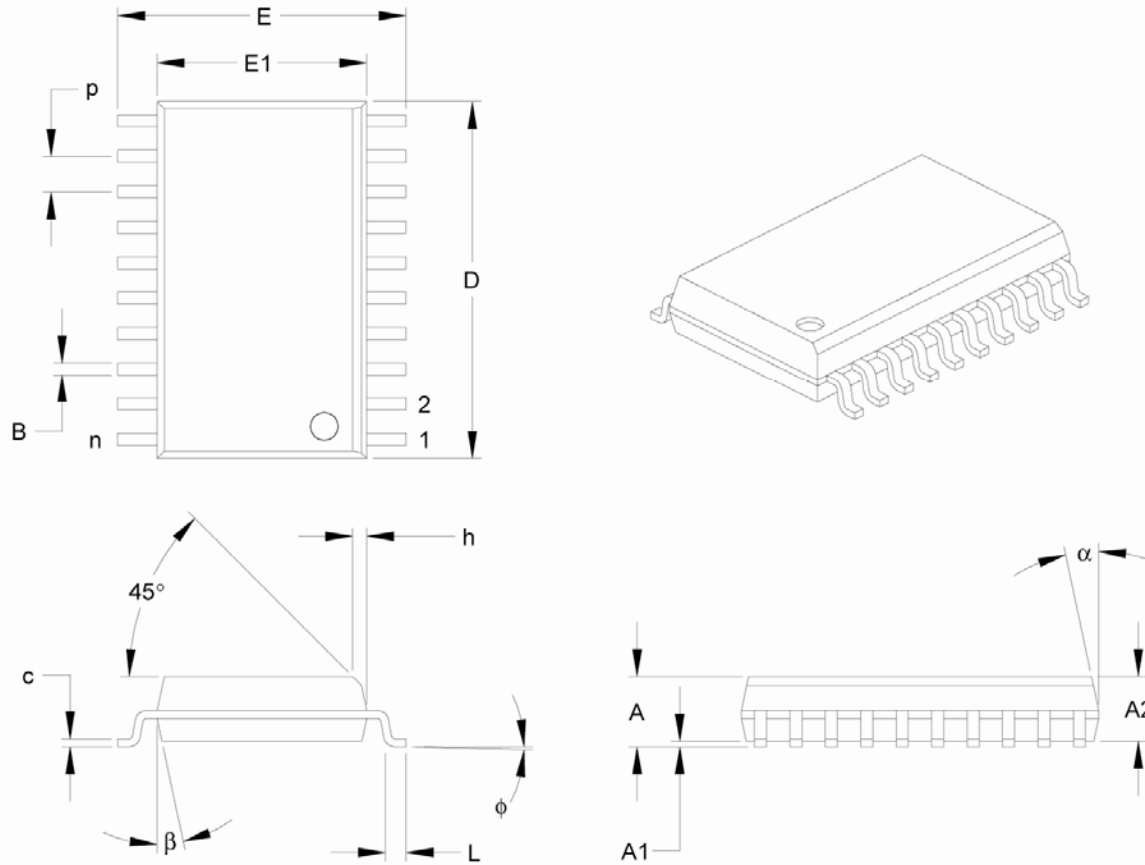

Dimension Limits	Units	INCHES*			MILLIMETERS		
		MIN	NOM	MAX	MIN	NOM	MAX
Number of Pins	n		20			20	
Pitch	p		.050			1.27	
Overall Height	A	.093	.099	.104	2.36	2.50	2.64
Molded Package Thickness	A2	.088	.091	.094	2.24	2.31	2.39
Standoff	A1	.004	.008	.012	0.10	0.20	0.30
Overall Width	E	.394	.407	.420	10.01	10.34	10.67
Molded Package Width	E1	.291	.295	.299	7.39	7.49	7.59
Overall Length	D	.496	.504	.512	12.60	12.80	13.00
Chamfer Distance	h	.010	.020	.029	0.25	0.50	0.74
Foot Length	L	.016	.033	.050	0.41	0.84	1.27
Foot Angle	φ	0	4	8	0	4	8
Lead Thickness	c	.009	.011	.013	0.23	0.28	0.33
Lead Width	B	.014	.017	.020	0.36	0.42	0.51
Mold Draft Angle Top	α	0	12	15	0	12	15
Mold Draft Angle Bottom	β	0	12	15	0	12	15

\*Controlling Parameter

Notes:

Dimensions D and E1 do not include mold flash or protrusions. Mold flash or protrusions shall not exceed .010" (0.254mm) per side.

JEDEC Equivalent: MS-013

Drawing No. C04-094

TSHARC-12S 20 Pin SSOP Mechanical Specification

20-Lead Plastic Thin Shrink Small Outline (ST) – 4.4 mm (TSSOP)

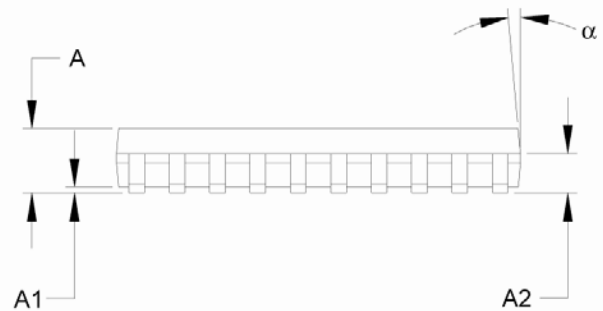
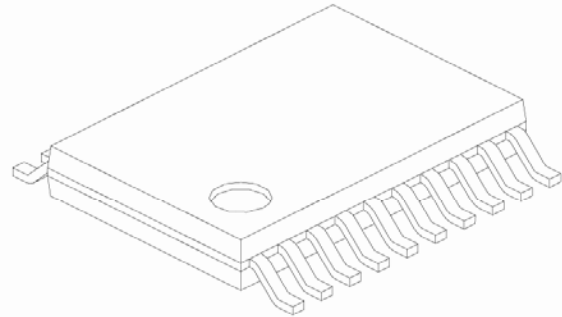
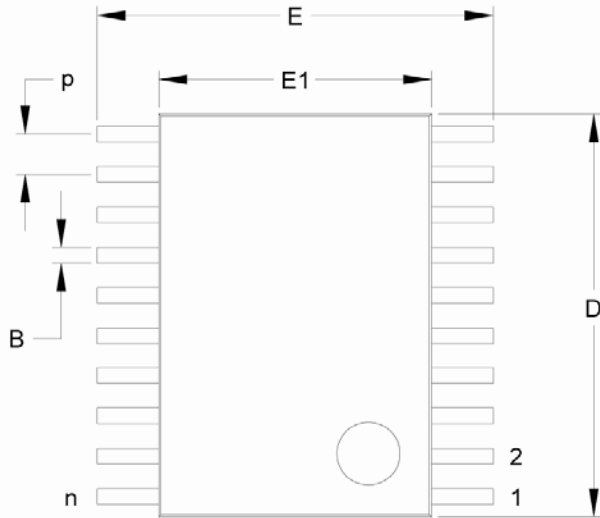

Dimension	Units	INCHES			MILLIMETERS*		
		MIN	NOM	MAX	MIN	NOM	MAX
Number of Pins	n		20			20	
Pitch	P		.026			0.65	
Overall Height	A	.039	.041	.043	1.00	1.05	1.10
Molded Package Thickness	A2	.033	.035	.037	0.85	0.90	0.95
Standoff	A1	.002	.004	.006	0.05	0.10	0.15
Overall Width	E	.246	.251	.256	6.25	6.38	6.50
Molded Package Width	E1	.169	.173	.177	4.30	4.40	4.50
Molded Package Length	D	.252	.256	.260	6.40	6.50	6.60
Foot Length	L	.020	.024	.028	0.50	0.60	0.70
Foot Angle	φ	0	4	8	0	4	8
Lead Thickness	c	.004	.006	.008	0.09	0.15	0.20
Lead Width	B	.007	.010	.012	0.19	0.25	0.30
Mold Draft Angle Top	α	0	5	10	0	5	10
Mold Draft Angle Bottom	β	0	5	10	0	5	10
*Controlling Parameter							
Notes:							
Dimensions D and E1 do not include mold flash or protrusions. Mold flash or protrusions shall not exceed .005" (0.127mm) per side.							

JEDEC Equivalent: MO-153

Drawing No. C04-088

## TSHARC-12S Schematic / Bill of Material Reference Matrix

**TSHARC Chip Model:** TSHARC-12S  
**Part Number(s):**  
**Resolution:** 12-Bit  
**Available chips packages:** 20-pin SOIC HS12-100S0s/12SS30  
 20-pin SSOP HS12-100P0s/12PS30  
**Reference Controller Board:** TSHARC-12V Board  
**Schematic:** See applicable schematic located in this document  
**Communication:** RS232 and PS/2, TTL and SPI also available  
**Touch Screens Supported:** 4, 5 and 8 wire analog resistive touch sensors  
 \*BOM and Schematics may be implemented with a 3.3V or 5V 12S chip product.

Document	4-wire	5-wire	8-wire	RS-232	PS/2	SPI	TTL
SB-101015	x	x	x	x	x		x
SB-103015	x	x	x			x	



The schematics available are tested designs created by Microchip Technology, Inc. Special attention has been taken to optimize the performance of the touch controller circuitry in these designs. Different configurations of the existing design are available, as shown in the various published schematics. Any deviations from any of these designs may impact the overall implemented design in a negative way. Microchip Technology, Inc. does not recommend any changes or deviations from what is shown within the published TSHARC schematics. Microchip Technology, Inc. offers free schematic reviews as a complimentary service to assist design teams in the integration of TSHARC touch controllers.

### Application Notes

- 1) Please contact Hampshire Company to ensure that you have the latest schematic and Bill of Material before proceeding with your final design. While Hampshire cannot accept any responsibility for your final design, it is recommended that you contact Hampshire support via telephone or via the support web page before proceeding with your production.

Also, to ensure our ability to support your embedded application of the TSHARC touch screen controller chip we ask that you send us a copy of your touch screen controller schematics drawings for your customer file. This is helpful if you require support sometime in the future. We offer this review service free of charge with any of our controller chips. Hampshire does not share this information with any third party.

Phone: 414-355-4675

Email: [support@hampshirecompany.com](mailto:support@hampshirecompany.com)

- 2) H2 touch screen connection header.  
 This header is used to connect variations of 4 or 5 wire sensors. Some or all may be designed into your circuit to ensure future flexibility to choose a variety of touch screen manufacturers touch screens.  
 Recommendation: Design in as many of these as you can. See Hampshire's reference "12V" controller board or contact Hampshire sales engineer to find ideas how you may maximize your touch screen compatibility matrix.
- 3) Make sure to keep all analog circuits away from high power and inverter circuits traces. Failure to follow this guideline will reduce your controller performance and/or accuracy.
- 4) PS/2 timing can change between different BIOS and PCs. Please make sure you have control of this variable before developing a PS/2 touch solution. If this control is not in place, other communication protocols are available with the 12s chip and other TSHARC products
- 5) Jumpers are used to configure the operation mode of the TSHARC-12S controller.

JP1	JP2	JP3	Operation Mode
X	X		4-Wire RS232
	X		5-Wire RS232
X	X	X	8-Wire RS232
X			4-Wire RS/2
			5-Wire PS/2
X		X	8-Wire PS/2

**Table 6: Jumper Configuration for S-101015**

JP1	JP3	Operation Mode
X		4-Wire SPI
		5-Wire SPI
X	X	8-Wire SPI

**Table 7: Jumper Configuration for S-103015**

TSHARC-12s: RS/232, PS/2, Direct to UART (TTL) / 4-,5-,7,8 wire

Note: For 4-,5- & 8 wire touch screens use HS12-100x0s chip.  
 For 4-,7 & 8 wire touch screens use HS12-101x0s chip.  
 Where: x = chip package

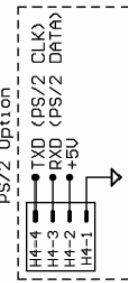
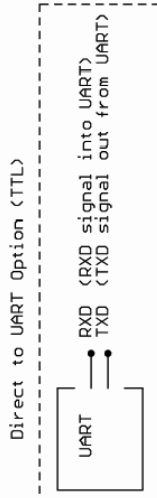
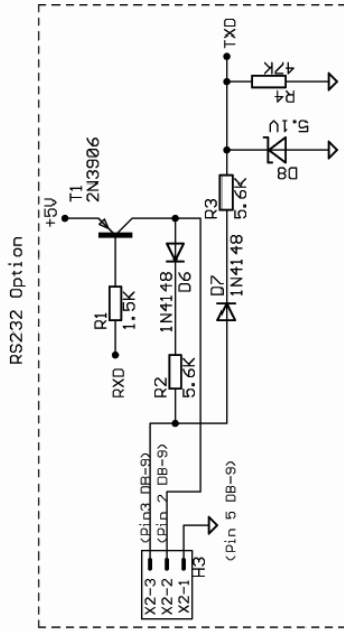
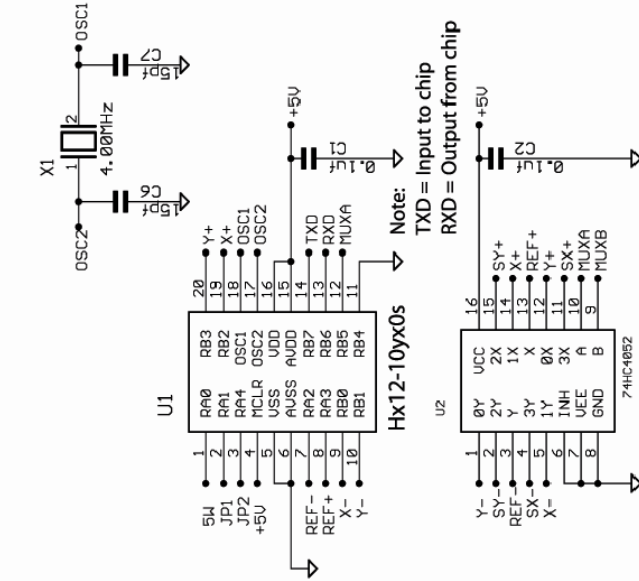
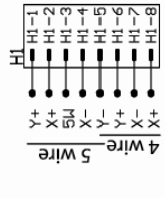

Jumpers

JP1	JP2	JP3	4 Wire RS232
X	X	X	5/7 Wire RS232
X	X	X	8 Wire RS232
X	X	X	4 Wire PS/2
X	X	X	5/7 Wire PS/2
X	X	X	8 Wire PS/2

X indicates installed

5 Wire Connections

Y+	Upper right
X-	Lower right
5W	5 Wire RS232
X+	Upper left
Y-	Lower left

Header H3 Connections

H3-8	RS232 GND
H3-7	Do not connect
H3-6	RS232 Transmit, DB9 pin 2
H3-5	RS232 Receive, DB9 pin 3
H3-4	PS/2 Data
H3-3	PS/2 Clk
H3-2	PS/2 Power +5V regulated
H3-1	Ground

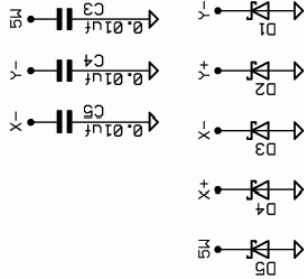

CONFIDENTIAL

TSHARC-12s: RS/232, PS/2, Direct to UART (TTL) / 4-,5-,7,8 wire

Document Number: S-101015

Hampshire Company, Inc.

Date: August 11, 2003

Sheet: 1/1

**Bill of Materials B-101015**

Item	Qty	Name	Manufactures Part#	Price	Description
U1	1	20 pin, TSHARC-12s	Hampshire Company, Inc Hx12-100x0s		Hampshire TSHARC-12 touch screen controller: DIP, SOIC, SSOP
C1, C2	2	0.1uf Cap	Panasonic: ECJ-3VB1E104K AVX: 12063C104KAT TDK: C3216X7R1E105K		0.1uf multilayer ceramic chip cap, 1206 pkg, Type X7R, +/- 10%, 25WV
C3, C4, C5	3	0.01uf Cap	Panasonic: ECJ-3VB1E103K AVX: 12063C103KAT TDK: C3216X7R1E104K		0.01uf multilayer ceramic chip cap, 1206 pkg, Type X7R +/- 10%, 25WV
X1	1	4.000 Mhz. crystal	ECS Quartz Crystals: ECS-40-S-4		4.000 MHz quartz crystal, HC-49/US pkg, Series
C6, C7	2	15 pf Cap	Panasonic: ECU-V1H150JCN AVX: 08051A150JAT2A NIC: NMC0805NPO150J100		15pf Multiplayer Ceramic chip Cap, 0805 pkg, Type NPO, +/- 5%, 50WV
JP1, JP2, JP3	3	0Ω Resistor	MuRata: CR0805-0000JTR AVX: CR21-000J NIC: NRC10J000TR Piher: RC05000JTR		0 Ω resistor, 5%, 1/10 watt, 0805 pkg
R5, R6, R7	3	10KΩ Resistor	Panasonic: ERJ-6GEYJ10K AVX: CR21-103J NIC: NRC10J103TR Piher: RC05103JTR		10KΩ thick film chip resistor, 5%, 1/10 watt, 0805 pkg
R4	1	47KΩ Resistor	Panasonic: ERJ-6GEYJ47K AVX: CR21-473J NIC: NRC10J473TR Piher: RC05473JTR		47KΩ thick film chip resistor, 5%, 1/10 watt, 0805 pkg
R2, R3	2	5.6KΩ Resistor	Panasonic: ERJ-6GEYJ5.6K AVX: CR21-562J NIC: NRC10J562TR Piher: RC05562JTR		5.6KΩ thick film chip resistor, 5%, 1/10 watt, 0805 pkg
R1	1	1.5KΩ	Panasonic: ERJ-6GEYJ1.5K AVX: CR21-152J-T NIC: NRC10J152TR Piher: RC05152JTR		1.5KΩ thick film chip resistor, 5%, 1/10 watt, 0805 pkg
T1	1	2N3906 Transistor	Fairchild: MMBT3906 Phillips: PMBT3906		2N3906 PNP transistor, 350mW, 40V, SOT-23 pkg.
D6, D7	2	1N4148 Diode	Diodes Inc. VISHAY: LL4148 Fairchild: FDLL4148T ITT: LL4148T		1N4148 high speed switching diode, 500mW, surface mount barrel pkg, DL-35, L=0.134", W=0.063", fits on 1206 pad
D8	1	5.1V Zenner	Diodes Inc. VISHAY: ZMM5231B		5.1V Zenner Diode, 500mW, surface mount barrel pkg. DL-35, L=0.13", W=0.063", fits on 1206 pad
D1, D2, D3, D4, D5	5	Transient Voltage Suppressor	AVX: VC120605D150		Transguard™ Transient Voltage Suppressor, 1206 package, 5.6V, 0.4 Joules
U2	1	HC4052 Dual channel MUX	Phillips: 74HC4052D Fairchild: MM74HC4052M SGS: M74HC4052M1R		HC4052 dual 4 channel multiplexer, 16 pin SOIC narrow pkg

TSHARC-12s: 3-wire interface SPI communication / 4, 5, 7, 8 wire

Note: For 4, 5, & 8 wire touch screens use HI12-100x0s chip.  
 For 4, 7 & 8 wire touch screens use HI12-101x0s chip.  
 Where: x = chip package

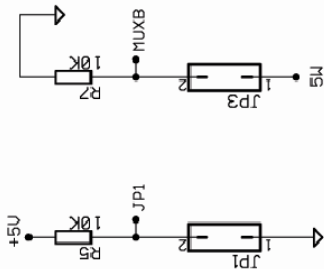

Jumpers

JP1	JP3
X	4 Wire
X	5,7 Wire
X	8 Wire
X indicates installed	

5 Wire Connections

Y+	Upper right
X-	Lower right
5W	Upper left
Y-	Lower left

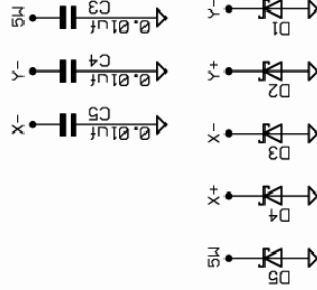
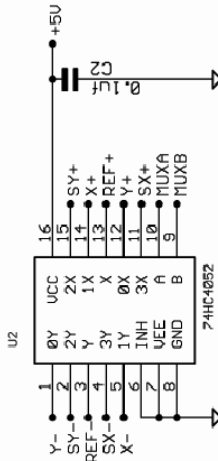
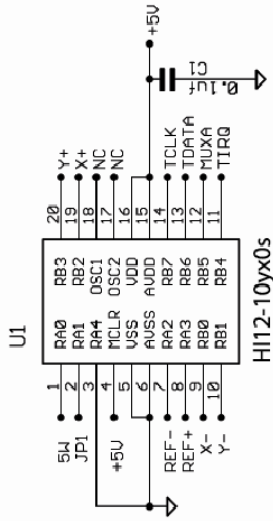
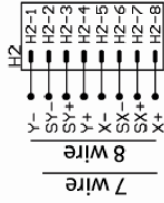
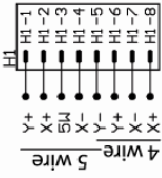

**CONFIDENTIAL**

TSHARC-12s: 3-wire interface SPI communication / 4, 5, 7, 8 wire

Document Number : S-103015  
 Hampshire Company, Inc.

Date: August 11, 2003

Sheet: 1/1

**Bill of Materials B-103015**

Item	Qty	Name	Manufactures Part#	Price	Description
U1	1	20 pin, TSHARC-12s	Hampshire Company, Inc HI12-10yx0s		Hampshire TSHARC-12 touch screen controller. DIP, SOIC, SSOP
C1, C2	2	0.1uf Cap	Panasonic: ECJ-3VB1E104K AVX: 12063C104KAT TDK: C3216X7R1E105K		0.1uf multilayer ceramic chip cap, 1206 pkg, Type X7R, +/- 10%, 25WV
C3, C4, C5	3	0.01uf Cap	Panasonic: ECJ-3VB1E103K AVX: 12063C103KAT TDK: C3216X7R1E104K		0.01uf multilayer ceramic chip cap, 1206 pkg, Type X7R +/- 10%, 25WV
JP1, JP3	2	0Ω Resistor	MuRata: CR0805-0000JTR AVX: CR21-000J NIC: NRC10J000TR Piherr: RC05000JTR		0 Ω resistor, 5%, 1/10 watt, 0805 pkg
R5, R7	2	10KΩ Resistor	Panasonic: ERJ-6GEYJ10K AVX: CR21-103J NIC: NRC10J103TR Piherr: RC05103JTR		10KΩ thick film chip resistor, 5%, 1/10 watt, 0805 pkg
D1, D2, D3, D4, D5	5	Transient Voltage Suppressor	AVX: VC120605D150		Transguard™ Transient Voltage Suppressor, 1206 package, 5.6V, 0.4 Joules
U2	1	HC4052 Dual channel MUX	Phillips: 74HC4052D Fairchild: MM74HC4052M SGS: M74HC4052M1R		HC4052 dual 4 channel multiplexer, 16 pin SOIC narrow pkg

preliminary



**Microchip Technology Inc.**

9055 N. 51st Street, Suite H

Brown Deer, WI 53223

Main Phone: 414-355-4675

Main Fax: 414-355-4775

[www.microchip.com/TSHARC](http://www.microchip.com/TSHARC)

Copyright Microchip Technology Inc. 1995 – 2009

Microchip<sup>®</sup>, TSHARC<sup>™</sup> and UniWinDriver<sup>™</sup> are trademarks of Microchip Technology Inc.

All rights reserved.

