

PNT Capabilities and Solutions





Who We Are

Our government systems business area provides high-performance, advanced timing systems primarily for the US DoD military and government organizations. We are a reliable partner for position, navigation and custom timing solutions for the most demanding applications. Many of our systems support 24/7 operations and have serviceable mission lives of 20+ years. Our fundamental understanding of mission applications and the impact of time and frequency accuracy on those applications enables us to serve as a trusted partner for our customers and facilitate the optimum utilization of their systems.

What We Do

- Deliver precise time and frequency systems to customers with the most stringent performance requirements
- Deliver time and frequency products for use in harsh environments, such as tactical, airborne and maritime
- Provide quick-reaction capability to adapt rapidly to changing customer requirements and market demands

PNT Capabilities

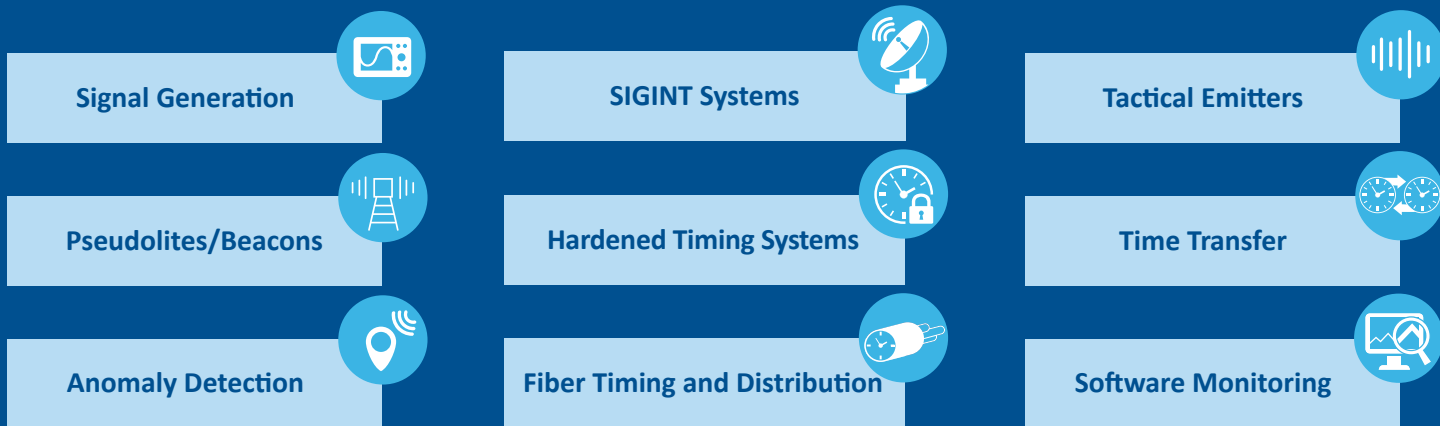



PNT Layers of Protection

We stand at a crucial point in military and critical infrastructure technology development, where the once readily available GPS position and time data can no longer be assumed as a constant during operations. The landscape has shifted to not merely protecting against Position, Navigation and Time (PNT) interference but to operate effectively in environments where PNT access is denied for extended periods of time. We have developed solutions for operations requiring several levels of PNT resilience.

- Pre-interruption
- Transient adversities, such as jamming and spoofing
- Extended denial

Time Transfer Techniques and Alternative Time Sources

We have decades of experience as the industry-leading provider of time transfer innovation. Our cutting-edge time transfer techniques and alternative timing capabilities enable resilient timing architectures for the most demanding CONOPS. Our time transfer capabilities include:

- Two-Way Satellite Time Transfer Modems (TWSTT)
- Two-Way Time Transfer—RF, coaxial and fiber (TWTT)
- eLORAN
- CPNT signal reception
- GPS common view
- Time transfer modems
- Satellite time and ranging systems

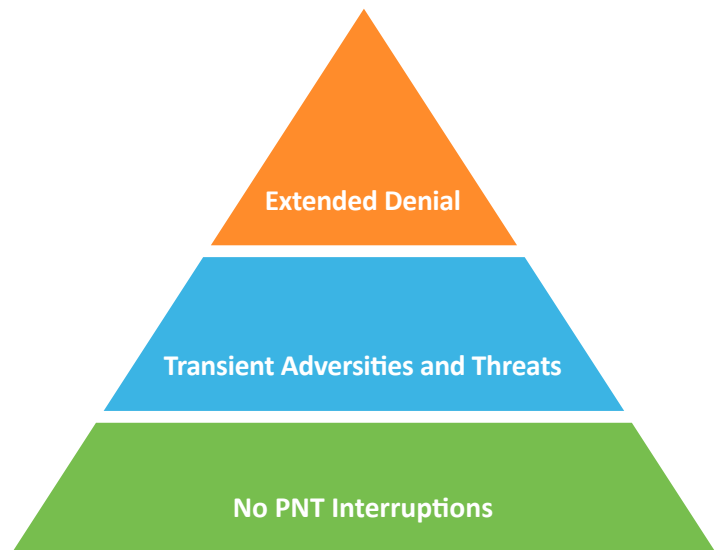



Site Timing Systems

Hardened Timing

Our hardened timing systems with semi-codeless access or M-Code provide superior time and frequency performance in a highly configurable 1U rack-mountable package with redundant and hot-swappable power supplies. This high-performance clock either leverages an internal rubidium atomic oscillator or connects with multiple external atomic references to provide accurate, long-term synchronization with Coordinated Universal Time (UTC) and excellent phase noise and short-term stability that aerospace, communications and defense applications require. These hardened timing systems include expansion ports for hot-swappable I/O modules that provide a wide array of timing signal outputs and high-resolution measurement input ports.



Precise Time Scale System

Our Precise Time Scale System (PTSS) is a fully integrated, world-class timing system that provides timing accuracies comparable to the world's best national laboratories. It often serves as the backbone for critical national infrastructure and an authoritative time source for contribution to UTC. The PTSS generates an autonomous time scale by combining several highly accurate, independent clocks. This system has an in-built multi-channel instrument for measuring high-performance cesium clocks or active hydrogen masers. These frequency standards operate in a free-running mode and are continuously measured against each other to compute UTC (Local) and generate the time scale frequency output performance. Multiple signal outputs can be distributed in a wide variety of formats.

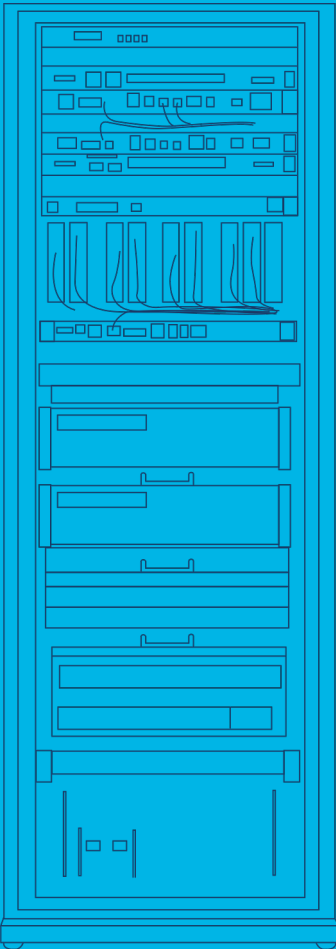

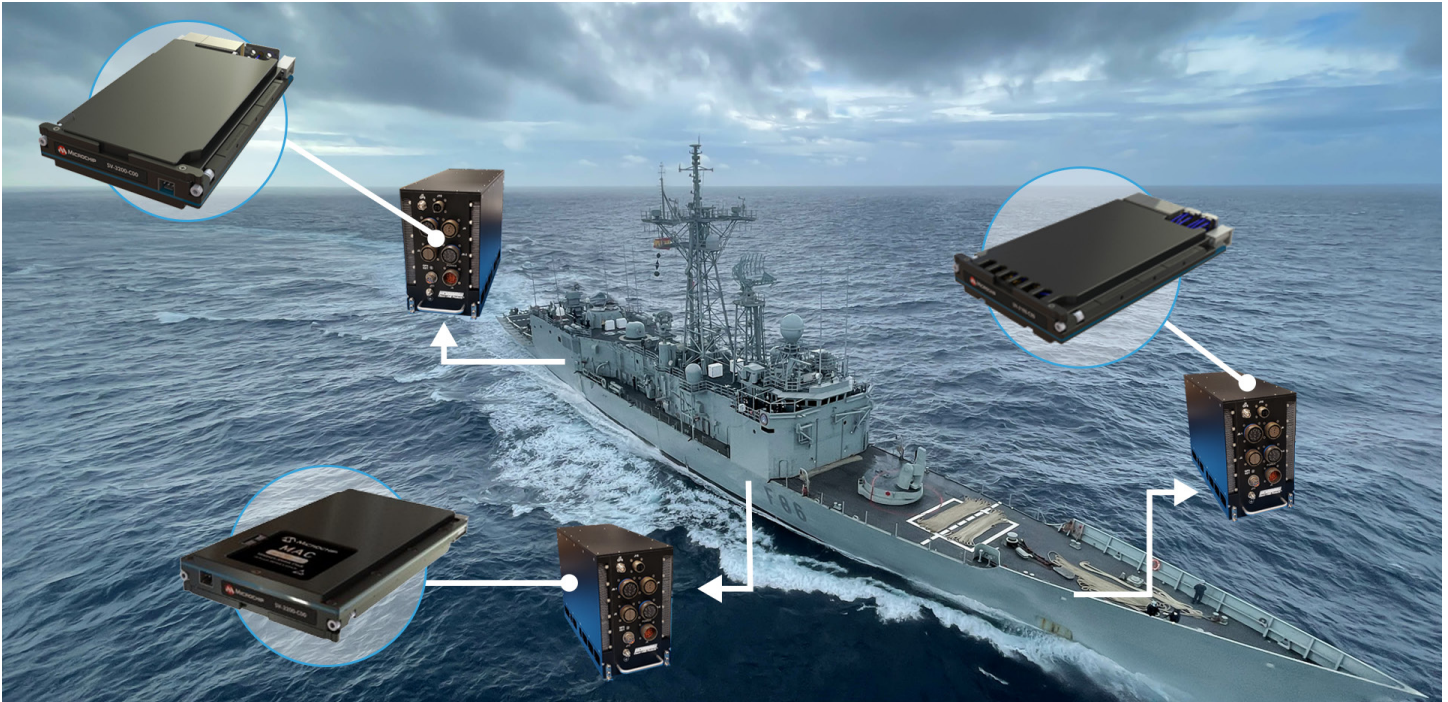

PNT Modules

Sensor Open System Architecture

As the market leader, we continually challenge conventional wisdom and are reinventing timing architectures to facilitate autonomous, adaptable and resilient operations. We have applied our timing expertise, developed over decades of engineering and thousands of field deployments, to a portfolio of OpenVPX plug-in cards. Our OpenVPX form-factor PNT products have been developed in alignment with the Sensor Open Systems Architecture (SOSA) Technical Standard and are based on the Modular Open System Approach (MOSA) and C5ISR Modular Open Suite of Standards (CMOSS) standards that enable PNT technologies to be interconnected without limitations.

GNSS Disciplined Modules

Our GNSS Disciplined Oscillator (GNSSDO) modules combine high-performance oscillators, atomic clock technology and our proprietary algorithms to create solutions that deliver higher-performance timing signals. These modules can be disciplined to a PPS signal from an M-Code or a GNSS receiver to provide excellent timing and holdover. The reference clock on these PPS-disciplined modules can be a quartz-based oscillator or an atomic clock. These modules can be integrated into a larger system as a high-performance time and synchronization subsystem.

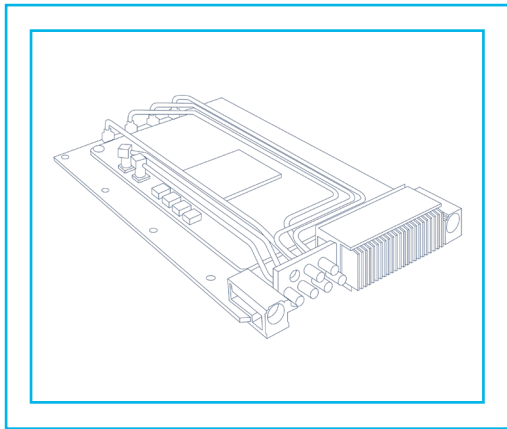
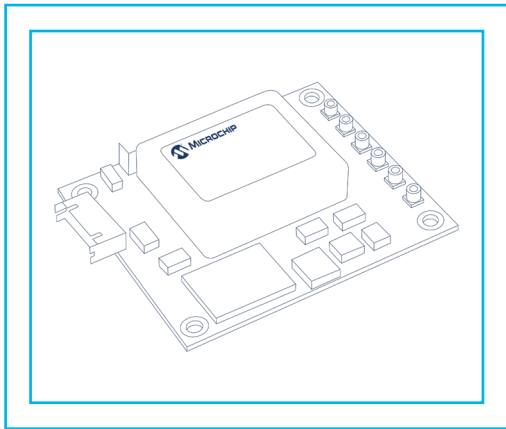



Portable PNT Systems

Our portable PNT products provide superior performance in a small lightweight package that is suited for military and intelligence applications. The combination of an internal atomic oscillator such as a Chip Scale Atomic Clock (CSAC) or a Miniature Atomic Clock (MAC), an M-Code receiver and an Inertial Motion Unit (IMU) allows for the accurate positioning, navigation and synchronization to authoritative reference with low phase noise and excellent short-term stability for signal collection applications.

These portable PNT systems provide signal fanout and can be customized with specialized signals and timecodes. Positioning data is also available and can be logged for subsequent post-processing or provided in real time via the Ethernet port.

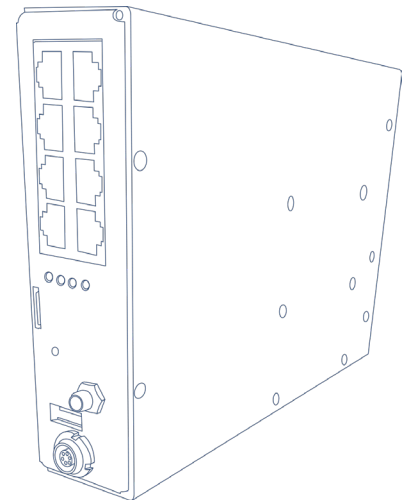

Tactical Emitter, Collection and SIGINT Systems

We produce several tactical, field-deployable, time-based reference emitters that generate synchronized RF signals that can be harmonized by a variety of references, including M-Code, atomic clocks or combinations of time sources. Waveform files can be used to synthesize signals with customized encoding schemes. Varying RF output power amplifiers and antennas are engineered to meet mission requirements. We have available a variety of commands and control via satellite networking. We also offer scalable SIGINT systems that digitize, time tag, packetize, archive and forward RF data for a variety of possible CONOPs.

Typical tactical systems support multiple active communication channels for continued operations. Enclosures designed for outdoor deployment that are sealed against moisture and conductively cooled are typically used to prevent penetration from outside elements. These systems are typically deployed in the harshest and most unforgiving of tactical environments. We are happy to work with you to customize our tactical SIGINT offerings to meet specific mission requirements.

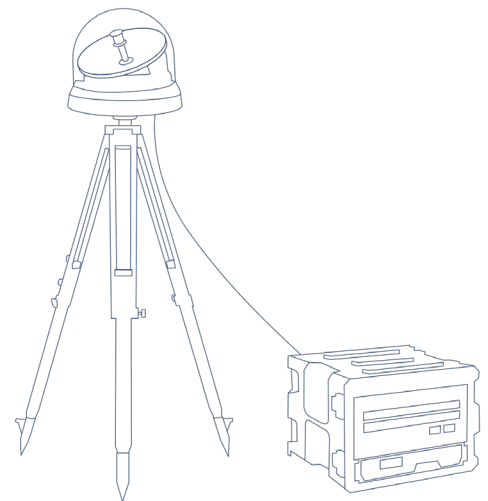



Packet Timing

The SyncServer® S650 M-Code modular time server combines the best of time and frequency instrumentation with flexibility and powerful network-based and security-hardened features. The timing output flexibility provides easy replication of precise and coherent output signals, which eliminates the need for a signal distribution chassis.

Other features include:

- Best-in-class, low-phase-noise, 10 MHz outputs for satellite ground stations and radar systems
- Multiple Gbps Ethernet (GbE) network ports for easily configured Network Time Protocol (NTP)/ Precision Time Protocol (PTP) operations
- Many security-hardened, network-based features for stringent IA requirements

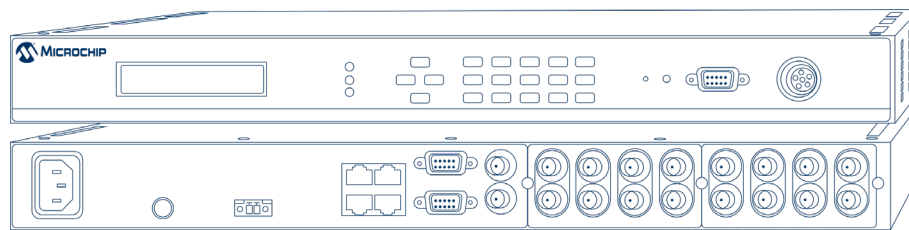

Our TimeProvider® 4500 (TP4500) series is the world's first IEEE® 1588 PTP Grandmaster with high-speed network interfaces that support up to 25 GbE and the flexibility to choose from 1 GbE, 10 GbE and 25 GbE options. This innovative hardware platform also enables the highest time accuracy below one nanosecond.

Key TP4500 features include:

- Enhancements such as the latest generation of synthesizer to enable the system to move into the picosecond realm
- Higher IEEE 1588 scalability to implement thousands of clients
- Supports PTP, NTP and SyncE
- Meets Primary Reference Time Clock (PRTC) Class A, Class B and enhanced PRTC (ePRTC) requirements and exceeds Class D for multi-domain boundary clocks
- Reliable, fanless passive thermal operation
- Redundancy via software mechanism using two active and standby units
- Patented, enhanced Assisted Partial Timing Support (APTS) with Automatic Asymmetry Compensation (AAC)
- Strong security and performance monitoring



GNSS Jamming and Spoofing Detection with Our BlueSky® GNSS Firewall

Our BlueSky GNSS Firewall protects deployed GNSS systems by providing a cost-effective overlay solution installed between existing GNSS antennas and GNSS systems. The BlueSky GNSS Firewall protects systems inside the firewall from untrusted sky-based signals outside the firewall. Features of the firewall include:

- Identification of GNSS system threats and protection from spoofing and jamming
- Seamless integration between existing GNSS antenna and GNSS system
- Optional rubidium Miniature Atomic Clock (MAC) can be installed inside the unit
- 1 PPS and 10 MHz timing reference inputs for extended holdover (for example, connection of external cesium reference)
- Redundant AC or DC power options with power monitoring and load sharing
- Local and remote Command Line Interface (CLI) in addition to secure and easy-to-use web interface
- Embedded software is field upgradeable, with new GNSS validation rules
- Integration with the TimePictra® software suite for end-to-end management of up to thousands of units from a single server
- Configurable GNSS thresholds: Carrier to noise, RF power, satellites in view, position deviation, phase deviation and more
- New Trusted Time anomaly detector for comparing network time and GNSS time
- New GPS subframe reference detection for comparing live-sky sub-frame data with sub-frame data received from a remote BlueSky GNSS Firewall





Services

We provide a variety of services that assist our government customers with the planning, design, testing, deployment and maintenance of local reference systems or enterprise-wide time and frequency infrastructure and everything in between. These services help lower costs, streamline processes, ensure quality and deliver the highest level of performance from your system or systems.

Our Mission

- Deliver precise time and frequency systems to customers with the most stringent performance requirements
- Deliver time and frequency products into harsh environments such as tactical, airborne and maritime
- Provide quick reaction capability to adapt rapidly to changing customer requirements and market

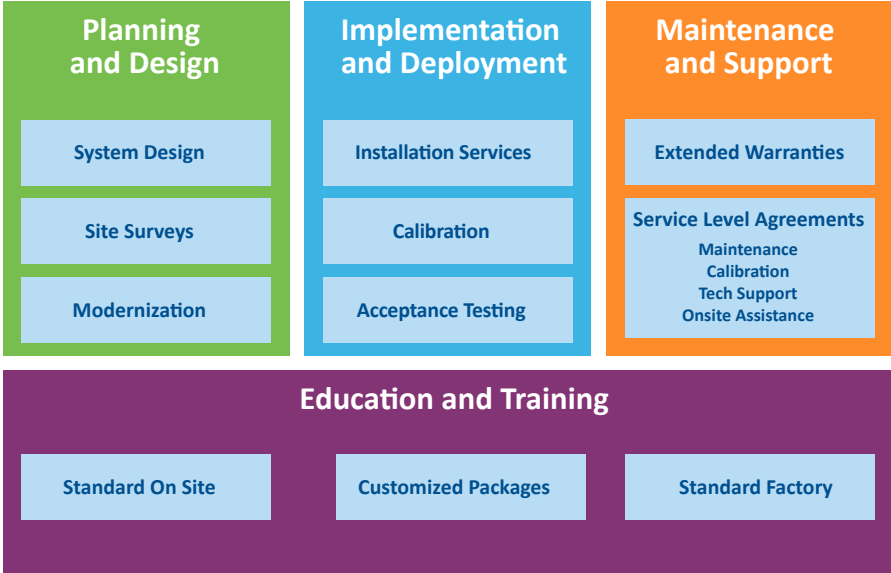

Our government systems team serves a wide variety of government customers, and our specialists provide comprehensive service solutions across a broad range of applications, including:

- Time and frequency solutions for government and defense applications
- High-precision frequency standards, including cesium atomic clocks, hydrogen masers and time scale systems that combine multiple time and frequency sources to produce a common timing standard
- Scalable time and frequency references, signal distribution systems and network time servers for a building, a campus or enterprise-wide systems
- Command/control, monitoring and measurement solutions for buildings, campuses and enterprise-wide systems



Our Services

Time Measurement and Analysis

Our government systems team has partnered with National Institute of Technology and Standards (NIST) to provide hardware and system support for a Time Measurement and Analysis Service (TMAS). This service helps you provide traceability of your site timing systems to an authoritative timing source like NIST. Often this traceability is a legal requirement, but it is also an easy way to characterize site timing accuracy.

Custom System Design

The government systems team has significant experience in designing and deploying custom timing systems for our federal customers. Our team will pull in the necessary pieces to provide an architecture designed to meet the immediate demands of current mission/program needs while providing the flexibility to address future needs. Application-specific architecture is reviewed with each customer for system performance, concept of operations, monitoring and maintenance.

Site Surveys

Site surveys describe exactly what is needed for a successful installation, covering all the details such as cable types/length, type of fiber and optimum GPS antenna locations (if applicable). Our site survey team will take the core of the system design and based on the desired installation location, develop a Bill of Materials (BoM) for the installation, including the rack(s), cabling, fiber and power needs. We will also conduct a comprehensive site review and look at your customer's needs and their locations to plan out the distribution infrastructure, equipment locations and connections. We will provide a pre-installation package that includes system drawings, wire lists, rack elevation drawings and a BoM for review. This package includes a pre-installation checklist to identify any issues before any installation work begins and identifies risks, so we can work toward their mitigation. The result is an all-inclusive statement of work that covers all installation responsibilities, without any hidden costs.

Modernization Planning

Many customers may already have a pre-existing time and frequency system in place. Technologies evolve over time, and we can help you develop a modernization plan by looking at the existing equipment and infrastructure. We can recommend the modifications needed to maximize the performance and life span for the system and its components. We can also provide drawings, a list of materials, system calibration and a transition plan to complete the work, while minimizing the impacts to the end users.



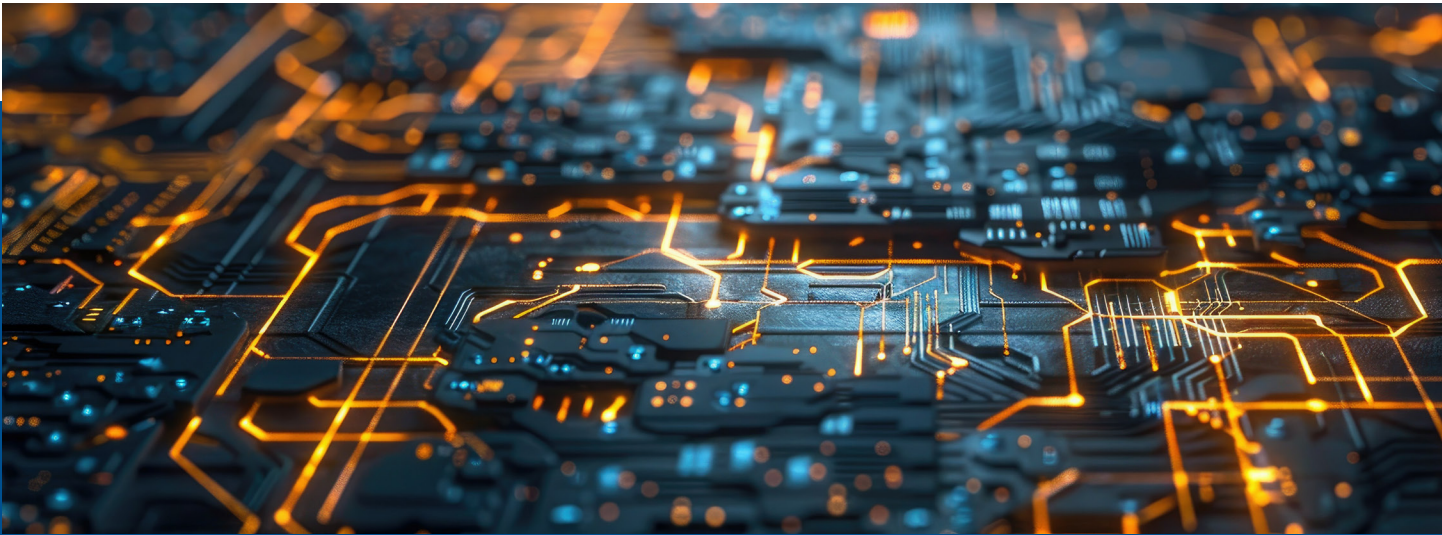

Our Services

Field Deployment and Installation

Our products are designed to operate in your unique and sophisticated environment, and when installed properly, our products will exceed your expectations. Deployment and implementation services facilitate proper and successful installation and system commissioning.

System Acceptance/Field Testing

Test and acceptance can be conducted at the factory and/or on-site at customer locations. Test criteria range from verifying individual product specifications to validating end-to-end system performance. The test and acceptance procedures verify that the installed equipment/systems meet your operational and performance requirements. The test criteria are based on industry standards and our experience in deployment of time and frequency solutions worldwide.

Technical Support

At the core of our maintenance services is the Microchip Government Systems Technical Support Team. We provide worldwide support for government customers, and this support is available 24 hours a day, 7 days a week, 365 days a year. Our team consists of system experts with an in-depth knowledge of our products and a deep understanding of the industry standards and customer systems. Most importantly, our team has years of hands-on experience that you can benefit from—in responding to routine questions and restoring system operations in emergency situations.

Maintenance and Calibration

To continue providing customers with long product lifecycles, we provide on-site maintenance to ensure that the system software/firmware is up to date, and all recommended routine maintenance is completed. Since these products are normally deployed in critical, high reliability timing applications, our maintenance and calibration service helps ensure your unit/system performance is meeting expectations. Maintenance and calibration services are available on an annual contract basis, include delivery of a report showing the maintenance completed, the current system accuracies, and the recommended changes based on the calibration results. These changes can be implemented prior to the team's departure if requested by the customer.





Contact Us

Please contact us if you have questions or want to further discuss our capabilities and solutions.

Contact Information:

Microchip, Frequency and Time Systems
Government Systems
4775 Walnut Drive, Suite 1B
Boulder, CO 80301-2579

For questions, please contact

Business Development: Rich Foster – rich.foster@microchip.com

Business Development: Chris Center – chris.center@microchip.com

Solutions Engineering: Kirk Montgomery – kirk.montgomery@microchip.com

Product Management: Greg Wolff – greg.wolff@microchip.com

Product Management: Evan Alexander – evan.alexander@microchip.com

Microchip Technology Inc. | 2355 W. Chandler Blvd. | Chandler AZ, 85224-6199 | microchip.com