

Introduction [\(Ask a Question\)](#)

PolarFire[®] SoC FPGA devices integrate a fifth-generation flash-based FPGA fabric architecture that includes embedded Math blocks optimized specifically for Digital Signal Processing (DSP) applications such as Finite Impulse Response (FIR) filters, Infinite Impulse Response (IIR) filters, and Fast Fourier Transform (FFT) functions.

This document describes the DSP FIR filter demo design and how to run the demo on a PolarFire SoC Discovery Kit. The DSP FIR filter demo is implemented using Libero[®] SoC. The demo design consists of:

- A 127 tap FIR filter with re-loadable coefficients.
- A 256 point FFT on filter output to view spectrum.
- An UART interface to the host PC to load the filter coefficients and input signals (low-pass, high-pass, band-pass, and band-stop frequencies).
- A Host PC GUI application to generate and interface with the demo design running on the PolarFire SoC FPGA device. The GUI also plots the input/output waveforms and the required spectrum.

Table of Contents

Introduction.....	1
1. Demo Requirements.....	3
2. Demo Design Description.....	4
2.1. Design Implementation.....	5
2.2. IP Blocks Used in the Design.....	5
2.3. Clocking Structure.....	6
2.4. Reset Structure.....	7
2.5. Simulating the Design.....	7
3. Board Setup.....	9
3.1. Powering Up the Board.....	9
3.2. Programming the Device Using FlashPro Express.....	9
4. Running the Demo.....	12
4.1. Installing and Starting the GUI.....	12
4.2. Generating the Filter Coefficients and Input Signal.....	12
4.3. Generating the Filter Output.....	14
5. Appendix 1: Running the Tcl Script.....	18
6. Appendix 2: References.....	19
7. Revision History.....	20
Microchip FPGA Support.....	21
Microchip Information.....	21
The Microchip Website.....	21
Product Change Notification Service.....	21
Customer Support.....	21
Microchip Devices Code Protection Feature.....	21
Legal Notice.....	22
Trademarks.....	22
Quality Management System.....	23
Worldwide Sales and Service.....	24

1. Demo Requirements [\(Ask a Question\)](#)

The following table lists the hardware and software requirements for the demo.

Table 1-1. Design Requirements

Requirements	Version
Operating System	Windows® 10
Hardware	
PolarFire® SoC Discovery Kit (MPFS-DISCO-KIT with FPGA: MPFS095T-1FC3G325E)	REV 2
Software	
FlashPro® Express	Available with Libero® SoC installation package.
Libero SoC	Note: Refer to the <code>readme.txt</code> file provided in the design files for the software versions used with this design.
GUI	The GUI is only supported on Windows 10.

Before you start:

1. Download the demo design files from www.microchip.com/en-us/application-notes/an5165. The design files folder contains the following sub-folders:
 - Programming_Job: Contains the programming `.job` file. The demo design is programmed using the `.job` file, see [Programming the Device Using FlashPro Express](#).
 - GUI_Installer: Contains the GUI installation package required to run the demo design.
 - TCL_Scripts: Contains the Tcl scripts for creating the demo design. For more information on creating the demo design using Tcl, see [Appendix 1: Running the Tcl Script](#).
2. Download and install [Libero SoC](#) on the host PC. To evaluate the designs using the PolarFire SoC Discovery Kit, use the free Libero SoC Silver license.

2.1. Design Implementation [\(Ask a Question\)](#)

This section shows the DSP Filter design implemented using the CoreFIR and CoreFFT IP cores in Libero SoC.

The following figure shows the top-level SmartDesign, which includes the clocking (PF_CCC_C0_0), Reset (CORERESET_PF_C0_0), the SmartDesign of DSP Flow (PFSOC_DSP_FLOW_TOP), and COREUART_C0_0.

Figure 2-2. Top-level SmartDesign

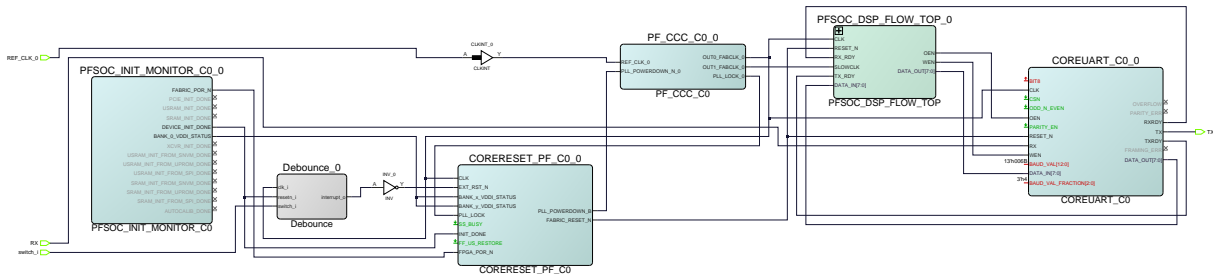

The following figure shows the PFSOC_DSP_FLOW_TOP SmartDesign, which includes FIR filter (COREFIR_PF_C0_0), FFT filter (COREFFT_PF_C0_0), buffers, control FSM and UART_IF blocks.

Figure 2-3. DSP FIR Filter SmartDesign

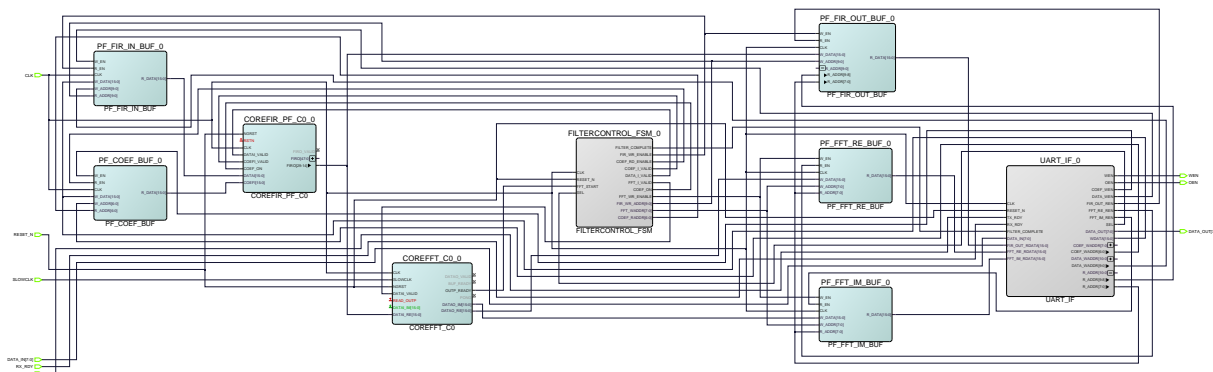

For more information on creating the demo design using Tcl, see [Appendix 1: Running the Tcl Script](#).

➔ Important: There is a known issue with the CoreFIR IP due to which the FIR output valid signal (FIR_VALID) is not used; instead, an initial latency of 128 cycles is used as a workaround. This will be fixed in the next release. This reference design and the associated GUI are created to support only the given CoreFIR and CoreFFT IP configurations.

2.2. IP Blocks Used in the Design [\(Ask a Question\)](#)

The following table lists the IP blocks used in the FIR filter design.

Table 2-1. IP Blocks

IP Block	Description
COREFIR_PF_C0	The COREFIR_PF_C0 IP is used in re-loadable coefficient mode to support low-pass, high-pass, band-pass, and band-stop filters.
COREFFT_C0	The COREFFT_C0 IP generates the frequency spectrum of the filtered data.
FILTERCONTROL_FSM_0	The filter control FSM block handles the data flow and controls signals of the FIR filter and FFT. It loads the filtered data with respect to the corresponding output buffer and moves the FFT output data to the corresponding FFT real and imaginary buffers.
UART_IF	The UART_IF block consists of a finite state machine for handling control operations between UART and the fabric logic. Control operations include the following: <ul style="list-style-type: none"> • Loading of filter coefficients. • Filtering input data with respect to the corresponding input data buffers and coefficient buffers. • Sending and receiving data from UART.
PF_TPSRAM	Five instances of PF_TPSRAM blocks are used in the design to store coefficients, FIR input data, FIR output data, FFT real, and FFT imaginary output data.
PF_CCC_C0	The PF_CCC_C0 IP is configured to take a 50 MHz reference clock as an input and generates 25 MHz and 200 MHz output clocks.

2.3. Clocking Structure [\(Ask a Question\)](#)

The following figure shows the clocking structure of the demo design.

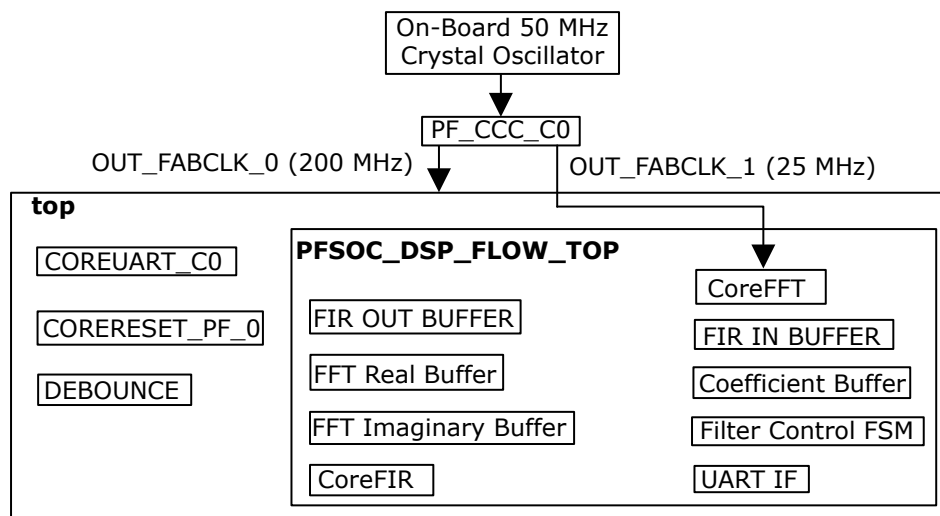
Figure 2-4. Clocking Structure

As shown in the preceding figure, the on-board 50 MHz crystal oscillator provides a reference clock to the PF_CCC_C0 block. PF_CCC_C0 generates the following clocks:

- 200 MHz clock that drives all the blocks of top_0 and PFSOC_DSP_FLOW_TOP
- 25 MHz slow clock is a secondary clock needed by the CoreFFT block which is within the PFSOC_DSP_FLOW_TOP

2.4. Reset Structure [\(Ask a Question\)](#)

The DEVICE_INIT_DONE, PLL Lock, and switch_i signals initiate the reset signal (FABRIC_RESET_N) from the CORERESET_PF_C0 block, which is synchronized with the OUT_FABCLK_0. The switch_i signal is connected to SW1 on the kit and this acts as external reset input to the design.

The following figure shows the reset structure of the demo design.

Figure 2-5. Reset Structure

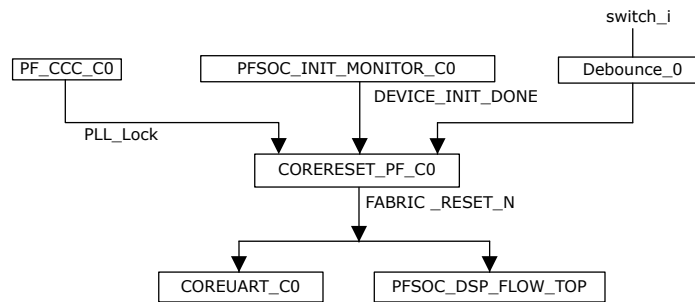

2.5. Simulating the Design [\(Ask a Question\)](#)

A testbench (top.v) is provided to simulate the design. The testbench simulates the filter pattern and waveform selection. It contains the test selection for the coefficient inputs (low-pass, high-pass, band-pass, and band-stop) and data input. It also monitors the UART_IF module status signals, output signals (DATAOUT), and FFT output status signals (DATA Valid and output ready) for the verification of filter output.

The following figure shows the simulation waveform.

Figure 2-6. CoreFIR Input and Output Signals

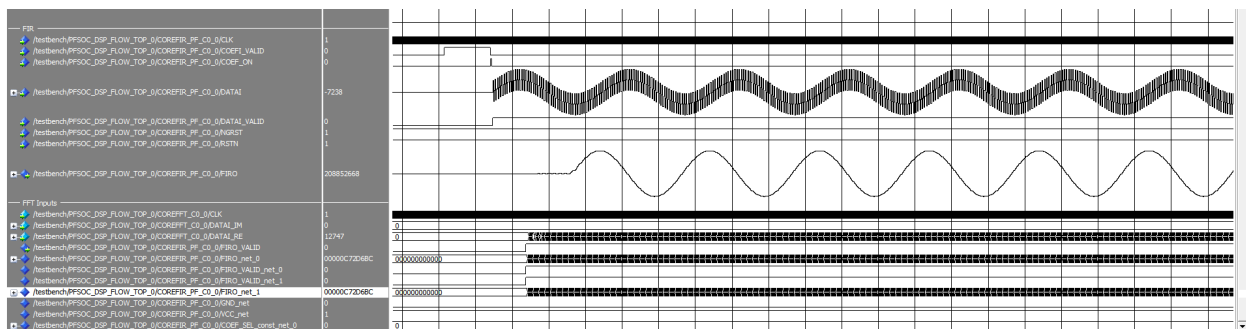

Important: To get this waveform, perform the following steps:

1. Change the radix of the input to decimal, right-click **DATAI**, go to the **radix** option, and select **decimal**.
2. Right-click **DATAI**, select the format option and select **Analog (automatic)**.

In the preceding figure:

- **COEFFI** represents Input coefficients
- **DATAI** represents FIR input data
- **FIRO** represents FIR output data

The following figure contains the Low-Pass Filter Output waveform, which is highlighted in the following figure.

Figure 2-7. Low-Pass Filter Output

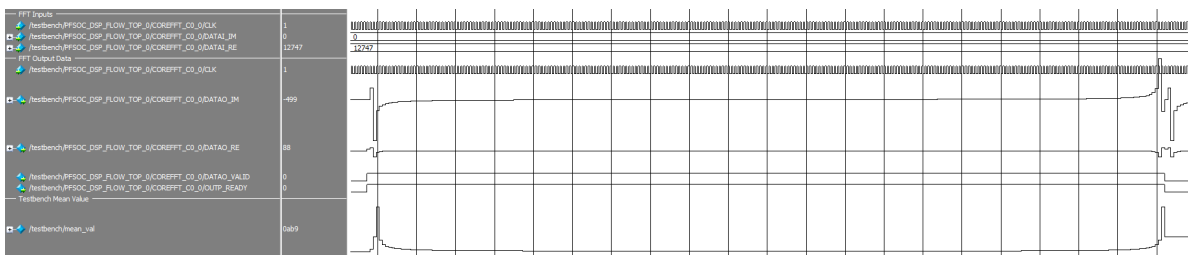

In the preceding figure:

- DATA_IM represents the imaginary part of the FFT output
- DATA_RE represents the real part of the FFT output

3. Board Setup [\(Ask a Question\)](#)

The board setup involves the following steps:

- [Powering Up the Board](#)
- [Programming the Device Using FlashPro Express](#)

3.1. Powering Up the Board [\(Ask a Question\)](#)

Before powering up the board, ensure that the jumper settings are the same as listed in the following table.

Table 3-1. Jumper Settings

Jumper	Setting	Description
J45	1 and 2 closed	To set Bank 1 and Bank 5 voltages (VDDI1_5) to 3.3V for Rpi GPIO and mikroBus operation
J46	1 and 2 closed	To set the VDDAUX1 voltage to 3.3V
J47	1 and 2 closed	To receive power from the USB Type-C port (J4) for the board
J49	2 and 3 closed	To set the 7 Segment display voltage to 5V

To power up the board, connect the Cable C Male to C Male cable from the USB Type-C port (J4) on the Discovery Kit to the Type C compatible (5V, 3A) port on the Host PC. The power status LEDs 5P0V, VDD, and 1P8V glow indicating that the board is powered-up.

3.2. Programming the Device Using FlashPro Express [\(Ask a Question\)](#)

This section describes the steps to program the PolarFire SoC device with the programming job file. The .job file is available at the following location in the provided design files:

```
mpfs_an5165_v2024p1_df/Programming_Job
```

To program a PolarFire SoC device using FlashPro Express, perform the following steps:

1. Ensure that all the steps described in [Board Setup](#) are completed.
2. On the host PC, launch the FlashPro Express software from the **Windows Start** menu.
3. Create a new job project by clicking **New**, as shown in the following figure.

Figure 3-1. FlashPro Express Job Project

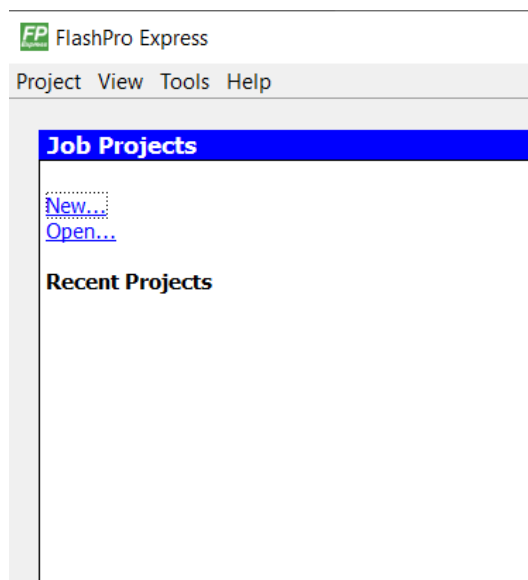

4. Enter the following in the **Create New Job Project** dialog box:
 - In the **Import FlashPro Express job file**: Click **Browse**, navigate to the location where the .job file is located, and select the file.
 - In the **FlashPro Express job project location**: Click **Browse** and navigate to the location where you want to save the project.

Figure 3-2. Creating New Job Project

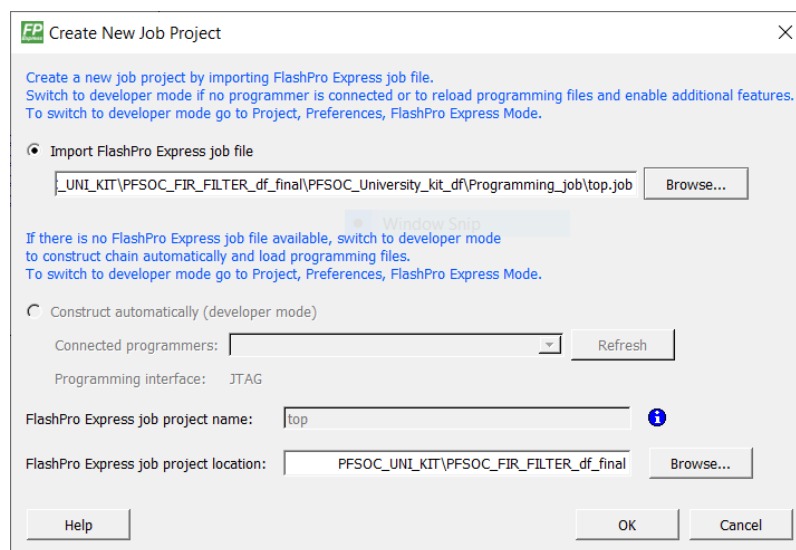

5. Click **OK**. The required programming file is selected and ready to be programmed in the device. The FlashPro Express window appears.
6. Verify that a programmer number appears in the **Programmer** box. If it does not show, verify the board connections, and click **Refresh/Rescan Programmers**.

Figure 3-3. Refresh/Rescan Programmiers

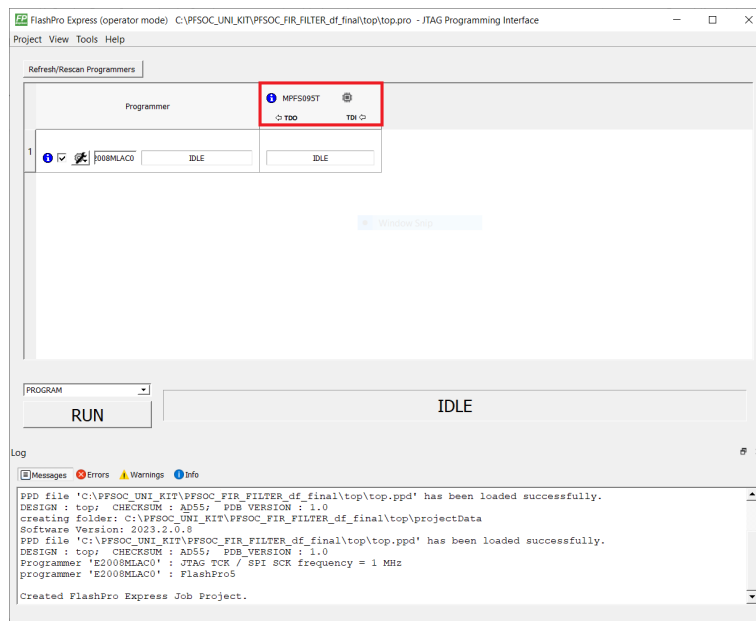

7. Click **RUN** to program the device. When the device is programmed successfully, a **RUN PASSED** status is displayed as shown in the following figure.

Figure 3-4. FlashPro Express-RUN PASSED

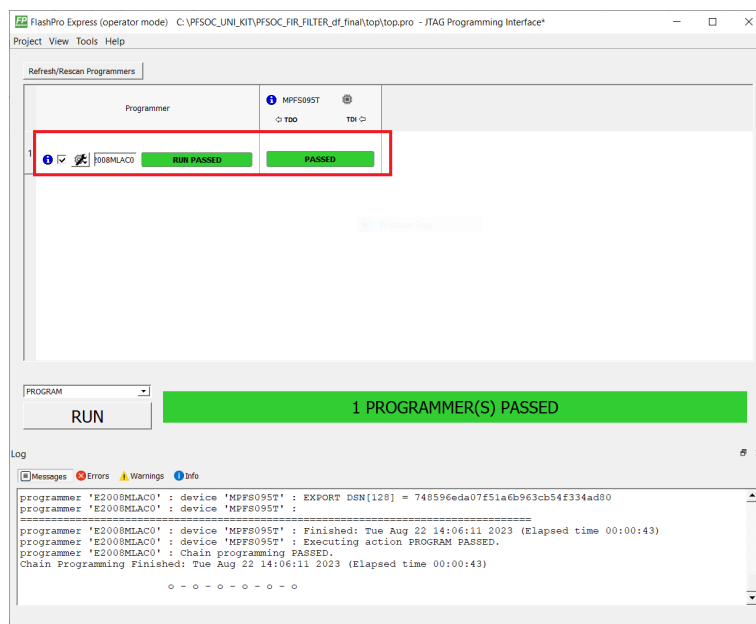

4. Running the Demo [\(Ask a Question\)](#)

Before you start, ensure that all the steps described in [Board Setup](#) are completed. Once the device is programmed, perform the following steps to run the demo:

1. [Installing and Starting the GUI](#)
2. [Generating the Filter Coefficients and Input Signal](#)
3. [Generating the Filter Output](#)

4.1. Installing and Starting the GUI [\(Ask a Question\)](#)

To install and start the GUI, perform the following steps:

1. Double-click the **DSP FIR Demo GUI** application (`setup.exe`) from the following location in the provided design files:
`mpfs_an5165_v2024p1_df/GUI_Installer/Volume`
2. Follow the installation wizard to install the GUI application.

4.2. Generating the Filter Coefficients and Input Signal [\(Ask a Question\)](#)

Follow these steps:

1. Launch the GUI and go to **Filter Settings** to generate the filter coefficients.
2. Retain the default **Filter Generation** parameters and select **Generate Filter** as shown in the following figure.

Figure 4-1. Filter Generation Parameters

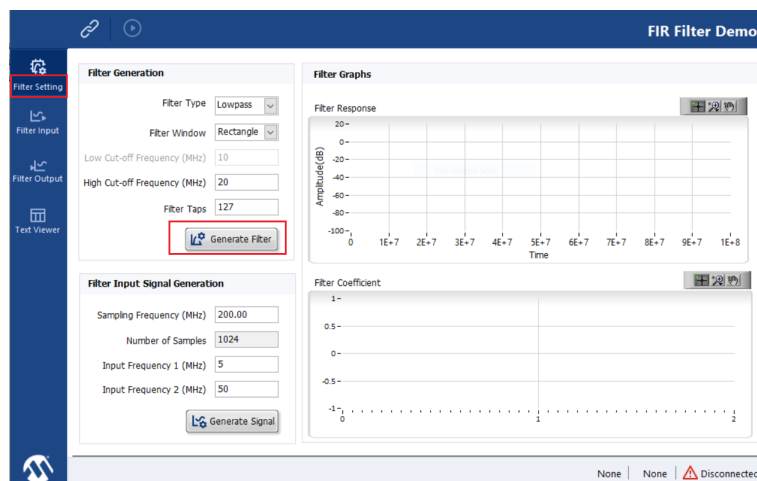

3. After generating the filter coefficients, the **Filter Response** and the **Filter Coefficient** plots are displayed as shown in the following figure.

Figure 4-2. Filter Response and Filter Coefficient

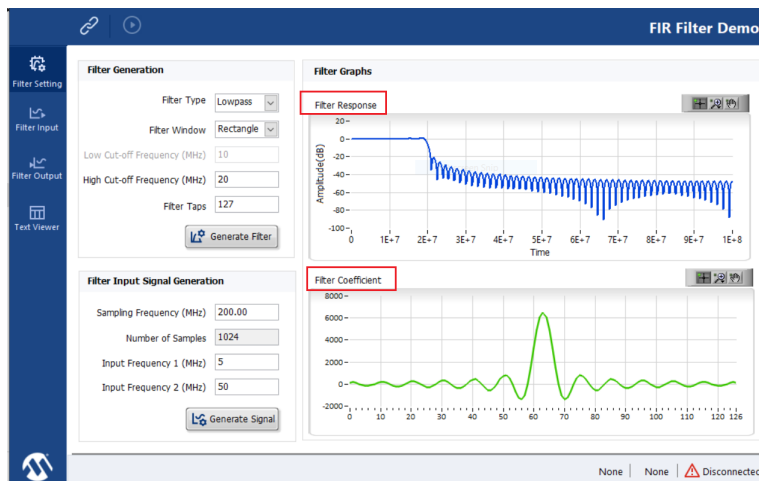

- To generate the input signals, retain the default parameters in the GUI and click **Generate Signal** as shown in the following figure.

Figure 4-3. Generate Signal

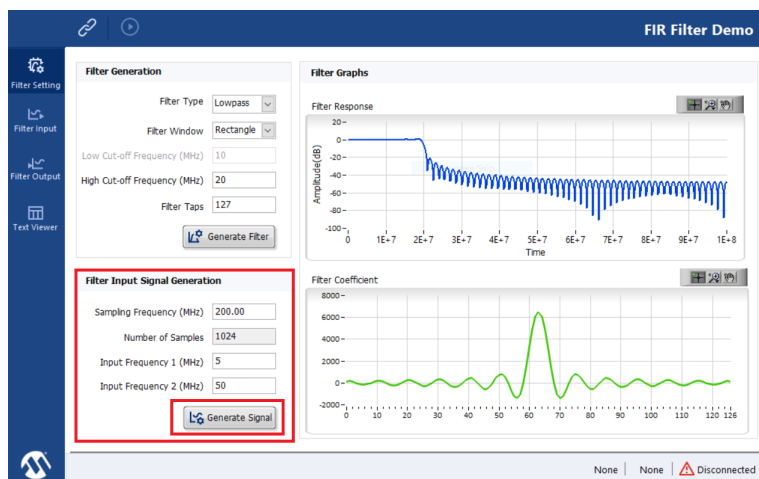

- The input signals and the frequency spectrum of the specified signals are displayed in the **Filter Input** tab, as shown in the following figure.

Figure 4-4. Filter Input Tab

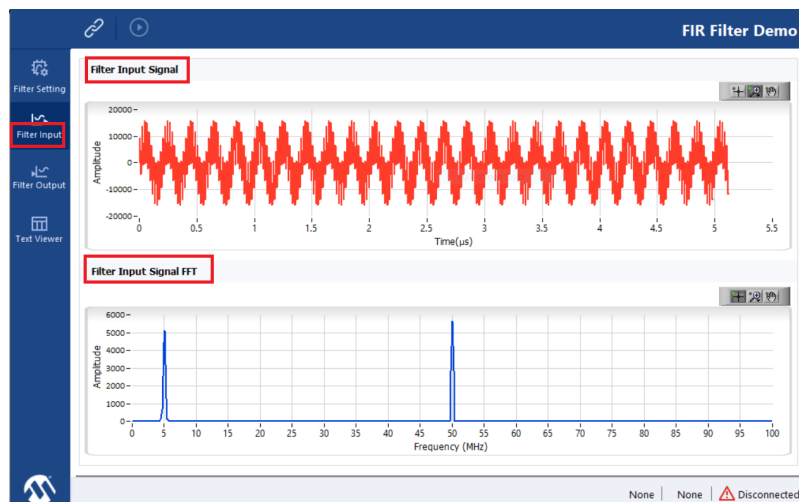

4.3. Generating the Filter Output [\(Ask a Question\)](#)

To generate the filter output, complete the following steps:

1. To configure the input frequencies and coefficients, click the  icon to connect as shown in the following figure.

Figure 4-5. Connect



2. After clicking the  icon, the GUI prompts you to press the **SW1** on the board and to click **OK** as shown in the following figure.

Figure 4-6. Establish Communication

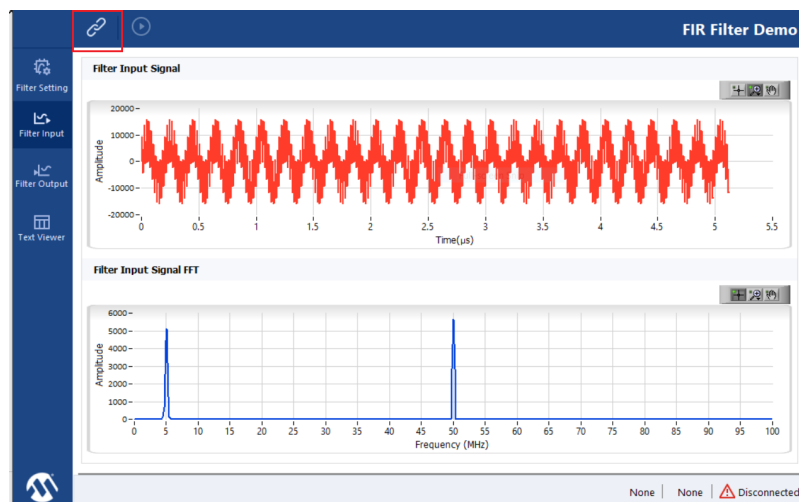

3. After clicking **OK**, click the  icon to start as shown in the following figure.

Figure 4-7. Start

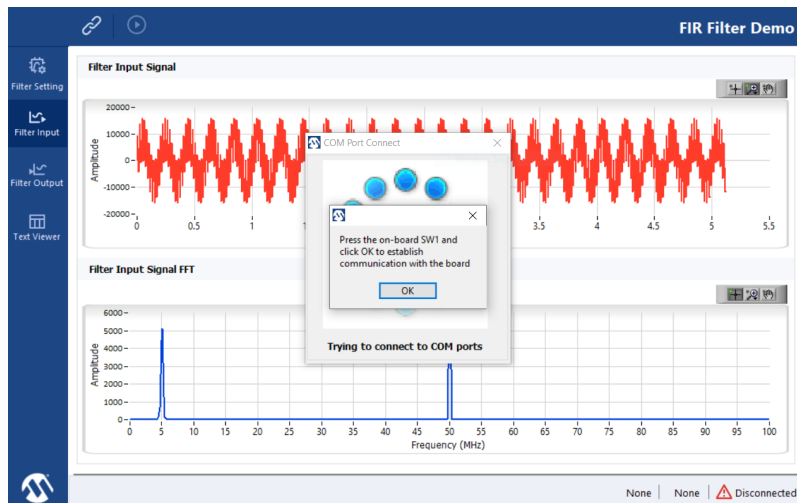

4. After clicking the  icon, the filter operation completes. The GUI displays the Operation Completed message and plots the filtered data and the FFT data on the **Filter Output** tab as shown in the following figure. As the low-pass filter option was selected, the high-frequency component is suppressed while the low-frequency signal is preserved. This is observable in the frequency spectrum of the output signal.

Figure 4-8. Filter Output Tab

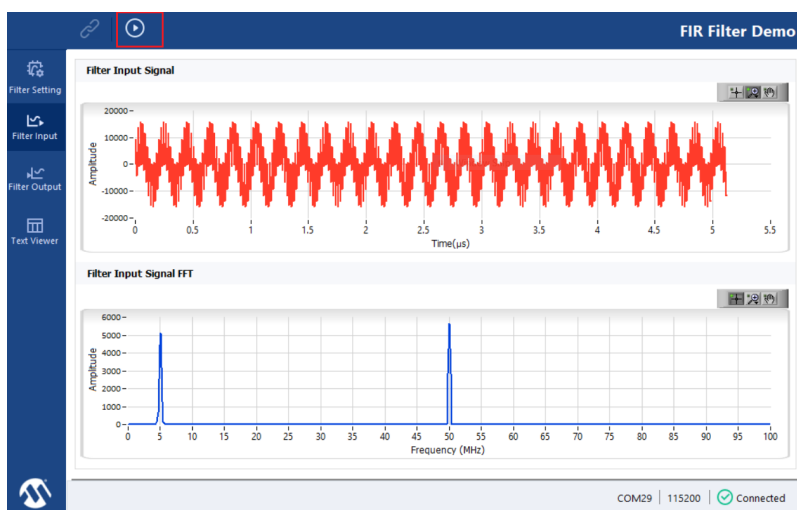

➔ Important: The accuracy of frequencies represented in the frequency plot depends on the frequency resolution used (sampling rate and FFT length).

- Zoom-in or zoom-out the waveform using the options shown in the following figure.

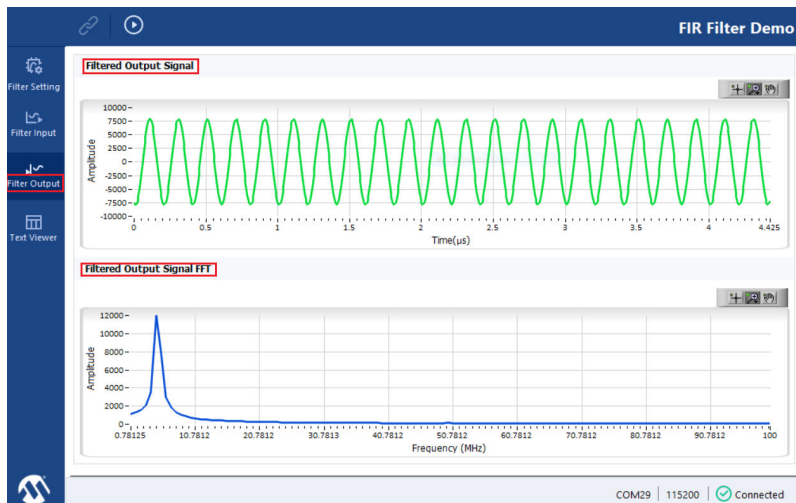
Figure 4-9. Zooming the Filter Output

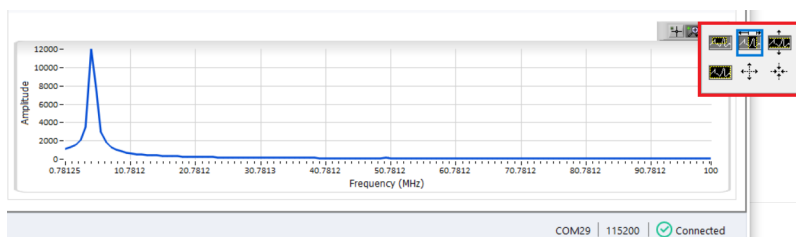

- The **Text Viewer** displays the filter coefficients, input signal, output signal, and FFT output data values, as shown in the following figure.

Figure 4-10. Text Viewer

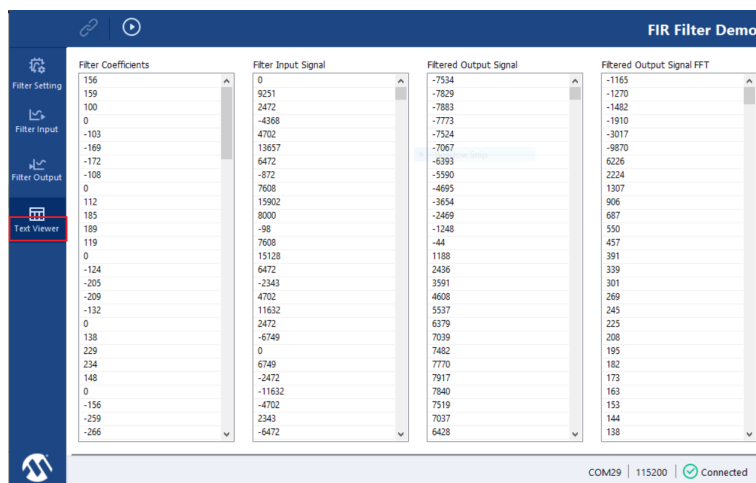

7. Close the GUI.

This concludes DSP FIR Filter demo.

5. Appendix 1: Running the Tcl Script [\(Ask a Question\)](#)

Tcl scripts are provided in the folders of design files under the directory `TCL_Scripts`. If necessary, the design flow can be reproduced from Design Implementation (which includes Synthesis, Place and Route, and Verify Timing) till the generation of the job file.

To run the Tcl, follow these steps:

1. Launch Libero SoC.
2. Select **Project > Execute Script**
3. Click **Browse** and select `script.tcl` from the downloaded `TCL_Scripts` directory.
4. Click **Run**.

After successful execution of the Tcl script, a Libero project is created within the `TCL_Scripts` directory.



Important: This is a known issue. When designs are executed on longer paths, they may fail. To prevent this, run the `.tcl` script (`script.tcl`) from shorter paths. It is recommended to download and save the TCL files closer to the root directory (for example, near the C drive) to ensure a shorter path.

For more information about Tcl scripts, see the `readme.txt` at `mpfs_an5165_v2024p1_df/TCL_Scripts`.

For more details on Tcl commands, see the [Tcl Commands Reference Guide](#). Contact the Technical Support team for any queries encountered while running the Tcl script.

6. Appendix 2: References [\(Ask a Question\)](#)

This section lists documents that provide more information about the DSP filters and IP cores used in the design.

- For more information about PF_TPSRAM, see the [PolarFire Family Fabric User Guide](#).
- For more information about PF_CCC, see the [PolarFire Family Clocking Resources User Guide](#).
- For more information about CoreFIR, see the [CoreFIR](#) page.
- For more information about CoreFFT, see the [CoreFFT](#) page.
- For more information about CoreUART, see the [CoreUART](#) page.
- For more information about Libero, ModelSim, and Synplify Pro, see the [Libero SoC Documentation](#).

7. Revision History [\(Ask a Question\)](#)

The revision history describes the changes that were implemented in the document. The changes are listed by revision, starting with the most current publication.

Table 7-1. Revision History

Revision	Date	Description
C	10/2024	The following is the list of changes made in Revision C of the document: <ul style="list-style-type: none">Added a Note regarding the TCL script in the Appendix 1: Running the Tcl Script section
B	04/2024	The following is the list of changes made in Revision B of the document: <ul style="list-style-type: none">Updated the document for Libero v2024.1.Updated the PolarFire SoC Discovery Kit (MPFS-DISCO-KIT) version from Rev 1 to Rev 2 in Table 1-1.Added a new GUI section in Table 1-1.Added a note about a known issue in section Design Implementation.Added the <code>top.v</code> testbench file name in section Simulating the Design.Removed the note “Output data is valid when FIRO_VALID is high.” in section Simulating the Design.Updated the folder name from v2023p2 to v2024p1 in section Programming the Device Using FlashPro Express.Updated the folder name from v2023p2 to v2024p1 in section Installing and Starting the GUI.Updated the folder name from v2023p2 to v2024p1 in Appendix 1: Running the Tcl Script.
A	12/2023	Initial release.

Microchip FPGA Support

Microchip FPGA products group backs its products with various support services, including Customer Service, Customer Technical Support Center, a website, and worldwide sales offices. Customers are suggested to visit Microchip online resources prior to contacting support as it is very likely that their queries have been already answered.

Contact Technical Support Center through the website at www.microchip.com/support. Mention the FPGA Device Part number, select appropriate case category, and upload design files while creating a technical support case.

Contact Customer Service for non-technical product support, such as product pricing, product upgrades, update information, order status, and authorization.

- From North America, call **800.262.1060**
- From the rest of the world, call **650.318.4460**
- Fax, from anywhere in the world, **650.318.8044**

Microchip Information

The Microchip Website

Microchip provides online support via our website at www.microchip.com/. This website is used to make files and information easily available to customers. Some of the content available includes:

- **Product Support** – Data sheets and errata, application notes and sample programs, design resources, user's guides and hardware support documents, latest software releases and archived software
- **General Technical Support** – Frequently Asked Questions (FAQs), technical support requests, online discussion groups, Microchip design partner program member listing
- **Business of Microchip** – Product selector and ordering guides, latest Microchip press releases, listing of seminars and events, listings of Microchip sales offices, distributors and factory representatives

Product Change Notification Service

Microchip's product change notification service helps keep customers current on Microchip products. Subscribers will receive email notification whenever there are changes, updates, revisions or errata related to a specified product family or development tool of interest.

To register, go to www.microchip.com/pcn and follow the registration instructions.

Customer Support

Users of Microchip products can receive assistance through several channels:

- Distributor or Representative
- Local Sales Office
- Embedded Solutions Engineer (ESE)
- Technical Support

Customers should contact their distributor, representative or ESE for support. Local sales offices are also available to help customers. A listing of sales offices and locations is included in this document.

Technical support is available through the website at: www.microchip.com/support

Microchip Devices Code Protection Feature

Note the following details of the code protection feature on Microchip products:

- Microchip products meet the specifications contained in their particular Microchip Data Sheet.
- Microchip believes that its family of products is secure when used in the intended manner, within operating specifications, and under normal conditions.
- Microchip values and aggressively protects its intellectual property rights. Attempts to breach the code protection features of Microchip product is strictly prohibited and may violate the Digital Millennium Copyright Act.
- Neither Microchip nor any other semiconductor manufacturer can guarantee the security of its code. Code protection does not mean that we are guaranteeing the product is “unbreakable”. Code protection is constantly evolving. Microchip is committed to continuously improving the code protection features of our products.

Legal Notice

This publication and the information herein may be used only with Microchip products, including to design, test, and integrate Microchip products with your application. Use of this information in any other manner violates these terms. Information regarding device applications is provided only for your convenience and may be superseded by updates. It is your responsibility to ensure that your application meets with your specifications. Contact your local Microchip sales office for additional support or, obtain additional support at www.microchip.com/en-us/support/design-help/client-support-services.

THIS INFORMATION IS PROVIDED BY MICROCHIP “AS IS”. MICROCHIP MAKES NO REPRESENTATIONS OR WARRANTIES OF ANY KIND WHETHER EXPRESS OR IMPLIED, WRITTEN OR ORAL, STATUTORY OR OTHERWISE, RELATED TO THE INFORMATION INCLUDING BUT NOT LIMITED TO ANY IMPLIED WARRANTIES OF NON-INFRINGEMENT, MERCHANTABILITY, AND FITNESS FOR A PARTICULAR PURPOSE, OR WARRANTIES RELATED TO ITS CONDITION, QUALITY, OR PERFORMANCE.

IN NO EVENT WILL MICROCHIP BE LIABLE FOR ANY INDIRECT, SPECIAL, PUNITIVE, INCIDENTAL, OR CONSEQUENTIAL LOSS, DAMAGE, COST, OR EXPENSE OF ANY KIND WHATSOEVER RELATED TO THE INFORMATION OR ITS USE, HOWEVER CAUSED, EVEN IF MICROCHIP HAS BEEN ADVISED OF THE POSSIBILITY OR THE DAMAGES ARE FORESEEABLE. TO THE FULLEST EXTENT ALLOWED BY LAW, MICROCHIP’S TOTAL LIABILITY ON ALL CLAIMS IN ANY WAY RELATED TO THE INFORMATION OR ITS USE WILL NOT EXCEED THE AMOUNT OF FEES, IF ANY, THAT YOU HAVE PAID DIRECTLY TO MICROCHIP FOR THE INFORMATION.

Use of Microchip devices in life support and/or safety applications is entirely at the buyer’s risk, and the buyer agrees to defend, indemnify and hold harmless Microchip from any and all damages, claims, suits, or expenses resulting from such use. No licenses are conveyed, implicitly or otherwise, under any Microchip intellectual property rights unless otherwise stated.

Trademarks

The Microchip name and logo, the Microchip logo, Adaptec, AVR, AVR logo, AVR Freaks, BesTime, BitCloud, CryptoMemory, CryptoRF, dsPIC, flexPWR, HELDO, IGLOO, JukeBlox, KeeLoq, Kleer, LANCheck, LinkMD, maXStylus, maXTouch, MediaLB, megaAVR, Microsemi, Microsemi logo, MOST, MOST logo, MPLAB, OptoLyzer, PIC, picoPower, PICSTART, PIC32 logo, PolarFire, Prochip Designer, QTouch, SAM-BA, SenGenuity, SpyNIC, SST, SST Logo, SuperFlash, Symmetricom, SyncServer, Tachyon, TimeSource, tinyAVR, UNI/O, Vectron, and XMEGA are registered trademarks of Microchip Technology Incorporated in the U.S.A. and other countries.

AgileSwitch, ClockWorks, The Embedded Control Solutions Company, EtherSynch, Flashtec, Hyper Speed Control, HyperLight Load, Libero, motorBench, mTouch, Powermite 3, Precision Edge, ProASIC, ProASIC Plus, ProASIC Plus logo, Quiet-Wire, SmartFusion, SyncWorld, TimeCesium, TimeHub, TimePictra, TimeProvider, and ZL are registered trademarks of Microchip Technology Incorporated in the U.S.A.

Adjacent Key Suppression, AKS, Analog-for-the-Digital Age, Any Capacitor, AnyIn, AnyOut, Augmented Switching, BlueSky, BodyCom, Clockstudio, CodeGuard, CryptoAuthentication, CryptoAutomotive, CryptoCompanion, CryptoController, dsPICDEM, dsPICDEM.net, Dynamic

Average Matching, DAM, ECAN, Espresso T1S, EtherGREEN, EyeOpen, GridTime, IdealBridge, IGaT, In-Circuit Serial Programming, ICSP, INICnet, Intelligent Paralleling, IntelliMOS, Inter-Chip Connectivity, JitterBlocker, Knob-on-Display, MarginLink, maxCrypto, maxView, memBrain, Mindi, MiWi, MPASM, MPF, MPLAB Certified logo, MPLIB, MPLINK, mSiC, MultiTRAK, NetDetach, Omniscient Code Generation, PICDEM, PICDEM.net, PICkit, PICtail, Power MOS IV, Power MOS 7, PowerSmart, PureSilicon, QMatrix, REAL ICE, Ripple Blocker, RTAX, RTG4, SAM-ICE, Serial Quad I/O, simpleMAP, SimpliPHY, SmartBuffer, SmartHLS, SMART-I.S., storClad, SQL, SuperSwitcher, SuperSwitcher II, Switchtec, SynchroPHY, Total Endurance, Trusted Time, TSHARC, Turing, USBCheck, VariSense, VectorBlox, VeriPHY, ViewSpan, WiperLock, XpressConnect, and ZENA are trademarks of Microchip Technology Incorporated in the U.S.A. and other countries.

SQTP is a service mark of Microchip Technology Incorporated in the U.S.A.

The Adaptec logo, Frequency on Demand, Silicon Storage Technology, and Symmcom are registered trademarks of Microchip Technology Inc. in other countries.

GestIC is a registered trademark of Microchip Technology Germany II GmbH & Co. KG, a subsidiary of Microchip Technology Inc., in other countries.

All other trademarks mentioned herein are property of their respective companies.

© 2025, Microchip Technology Incorporated and its subsidiaries. All Rights Reserved.

ISBN: 978-1-6683-0440-2

Quality Management System

For information regarding Microchip's Quality Management Systems, please visit www.microchip.com/quality.

Worldwide Sales and Service

AMERICAS	ASIA/PACIFIC	ASIA/PACIFIC	EUROPE
<p>Corporate Office 2355 West Chandler Blvd. Chandler, AZ 85224-6199 Tel: 480-792-7200 Fax: 480-792-7277 Technical Support: www.microchip.com/support Web Address: www.microchip.com</p> <p>Atlanta Duluth, GA Tel: 678-957-9614 Fax: 678-957-1455</p> <p>Austin, TX Tel: 512-257-3370</p> <p>Boston Westborough, MA Tel: 774-760-0087 Fax: 774-760-0088</p> <p>Chicago Itasca, IL Tel: 630-285-0071 Fax: 630-285-0075</p> <p>Dallas Addison, TX Tel: 972-818-7423 Fax: 972-818-2924</p> <p>Detroit Novi, MI Tel: 248-848-4000</p> <p>Houston, TX Tel: 281-894-5983</p> <p>Indianapolis Noblesville, IN Tel: 317-773-8323 Fax: 317-773-5453 Tel: 317-536-2380</p> <p>Los Angeles Mission Viejo, CA Tel: 949-462-9523 Fax: 949-462-9608 Tel: 951-273-7800</p> <p>Raleigh, NC Tel: 919-844-7510</p> <p>New York, NY Tel: 631-435-6000</p> <p>San Jose, CA Tel: 408-735-9110 Tel: 408-436-4270</p> <p>Canada - Toronto Tel: 905-695-1980 Fax: 905-695-2078</p>	<p>Australia - Sydney Tel: 61-2-9868-6733</p> <p>China - Beijing Tel: 86-10-8569-7000</p> <p>China - Chengdu Tel: 86-28-8665-5511</p> <p>China - Chongqing Tel: 86-23-8980-9588</p> <p>China - Dongguan Tel: 86-769-8702-9880</p> <p>China - Guangzhou Tel: 86-20-8755-8029</p> <p>China - Hangzhou Tel: 86-571-8792-8115</p> <p>China - Hong Kong SAR Tel: 852-2943-5100</p> <p>China - Nanjing Tel: 86-25-8473-2460</p> <p>China - Qingdao Tel: 86-532-8502-7355</p> <p>China - Shanghai Tel: 86-21-3326-8000</p> <p>China - Shenyang Tel: 86-24-2334-2829</p> <p>China - Shenzhen Tel: 86-755-8864-2200</p> <p>China - Suzhou Tel: 86-186-6233-1526</p> <p>China - Wuhan Tel: 86-27-5980-5300</p> <p>China - Xian Tel: 86-29-8833-7252</p> <p>China - Xiamen Tel: 86-592-2388138</p> <p>China - Zhuhai Tel: 86-756-3210040</p>	<p>India - Bangalore Tel: 91-80-3090-4444</p> <p>India - New Delhi Tel: 91-11-4160-8631</p> <p>India - Pune Tel: 91-20-4121-0141</p> <p>Japan - Osaka Tel: 81-6-6152-7160</p> <p>Japan - Tokyo Tel: 81-3-6880-3770</p> <p>Korea - Daegu Tel: 82-53-744-4301</p> <p>Korea - Seoul Tel: 82-2-554-7200</p> <p>Malaysia - Kuala Lumpur Tel: 60-3-7651-7906</p> <p>Malaysia - Penang Tel: 60-4-227-8870</p> <p>Philippines - Manila Tel: 63-2-634-9065</p> <p>Singapore Tel: 65-6334-8870</p> <p>Taiwan - Hsin Chu Tel: 886-3-577-8366</p> <p>Taiwan - Kaohsiung Tel: 886-7-213-7830</p> <p>Taiwan - Taipei Tel: 886-2-2508-8600</p> <p>Thailand - Bangkok Tel: 66-2-694-1351</p> <p>Vietnam - Ho Chi Minh Tel: 84-28-5448-2100</p>	<p>Austria - Wels Tel: 43-7242-2244-39 Fax: 43-7242-2244-393</p> <p>Denmark - Copenhagen Tel: 45-4485-5910 Fax: 45-4485-2829</p> <p>Finland - Espoo Tel: 358-9-4520-820</p> <p>France - Paris Tel: 33-1-69-53-63-20 Fax: 33-1-69-30-90-79</p> <p>Germany - Garching Tel: 49-8931-9700</p> <p>Germany - Haan Tel: 49-2129-3766400</p> <p>Germany - Heilbronn Tel: 49-7131-72400</p> <p>Germany - Karlsruhe Tel: 49-721-625370</p> <p>Germany - Munich Tel: 49-89-627-144-0 Fax: 49-89-627-144-44</p> <p>Germany - Rosenheim Tel: 49-8031-354-560</p> <p>Israel - Hod Hasharon Tel: 972-9-775-5100</p> <p>Italy - Milan Tel: 39-0331-742611 Fax: 39-0331-466781</p> <p>Italy - Padova Tel: 39-049-7625286</p> <p>Netherlands - Drunen Tel: 31-416-690399 Fax: 31-416-690340</p> <p>Norway - Trondheim Tel: 47-72884388</p> <p>Poland - Warsaw Tel: 48-22-3325737</p> <p>Romania - Bucharest Tel: 40-21-407-87-50</p> <p>Spain - Madrid Tel: 34-91-708-08-90 Fax: 34-91-708-08-91</p> <p>Sweden - Gothenberg Tel: 46-31-704-60-40</p> <p>Sweden - Stockholm Tel: 46-8-5090-4654</p> <p>UK - Wokingham Tel: 44-118-921-5800 Fax: 44-118-921-5820</p>